

# SOFIA: NASA's Stratospheric Observatory for Infrared Astronomy

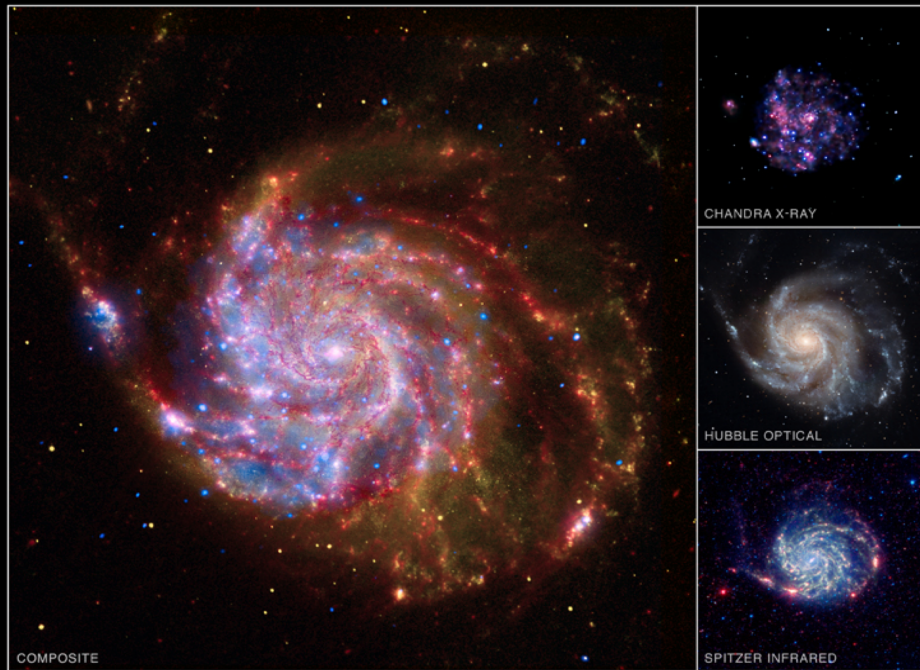

D. Backman -- SOFIA Outreach / SETI Institute / NASA-Ames  
CSU Long Beach -- March 5, 2012

# Outline

- ◆ The SOFIA Mission
  - Why build an airborne telescope?  
(background information about infrared astronomy)
  - SOFIA's advantages & capabilities
  - First-generation instrument set
- ◆ SOFIA's Science and Cosmic Evolution
  - Star and planet formation
  - Stellar and galactic evolution
  - Interstellar chemistry and organic molecules
  - Planets and planetary evolution
- ◆ SOFIA's Airborne Astronomy Ambassadors

# William Herschel

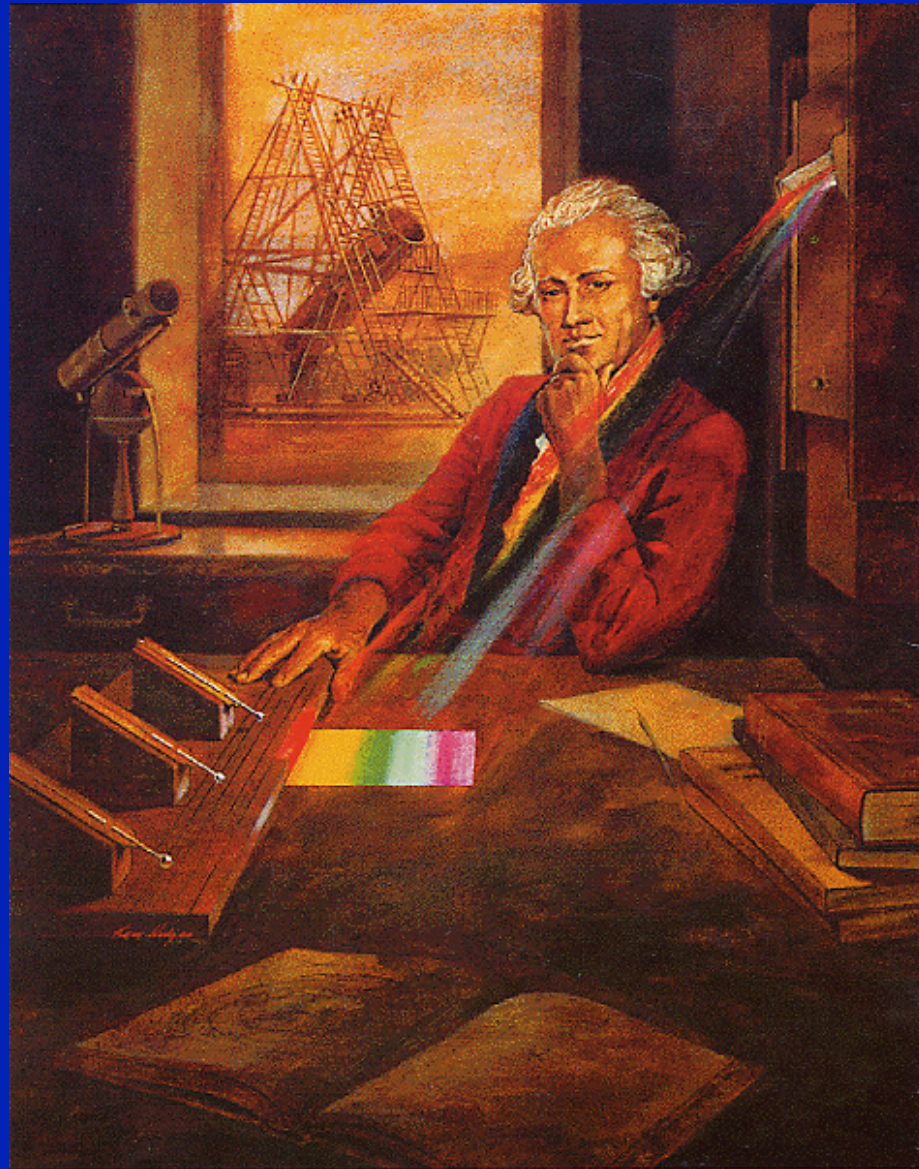

Discovery of Infrared Radiation - 1800

# The full electromagnetic spectrum ...

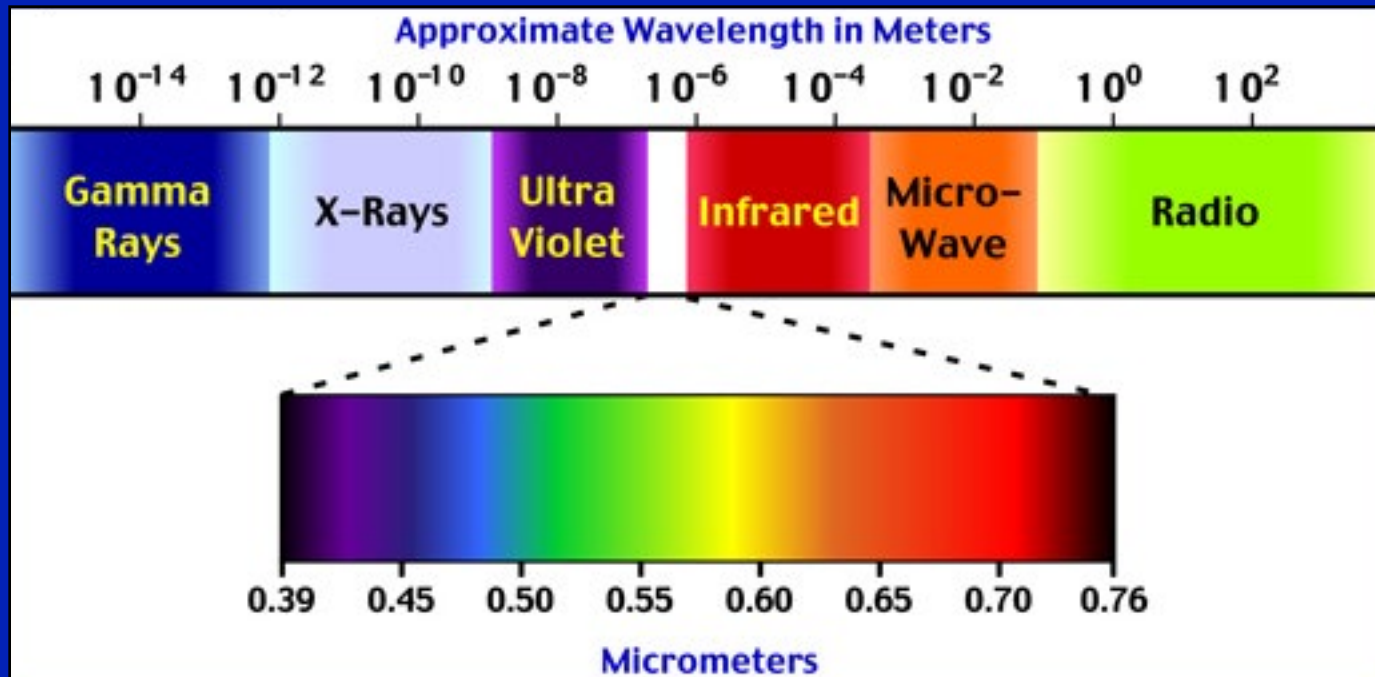

Making Light of it All!

# Getting the WHOLE picture

- ◆ An object can appear radically different depending on the type of light collected from it:

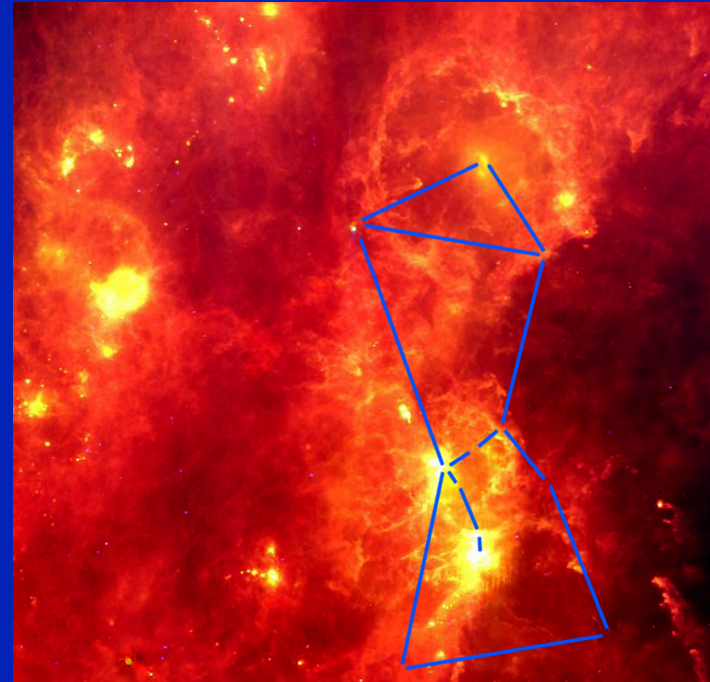
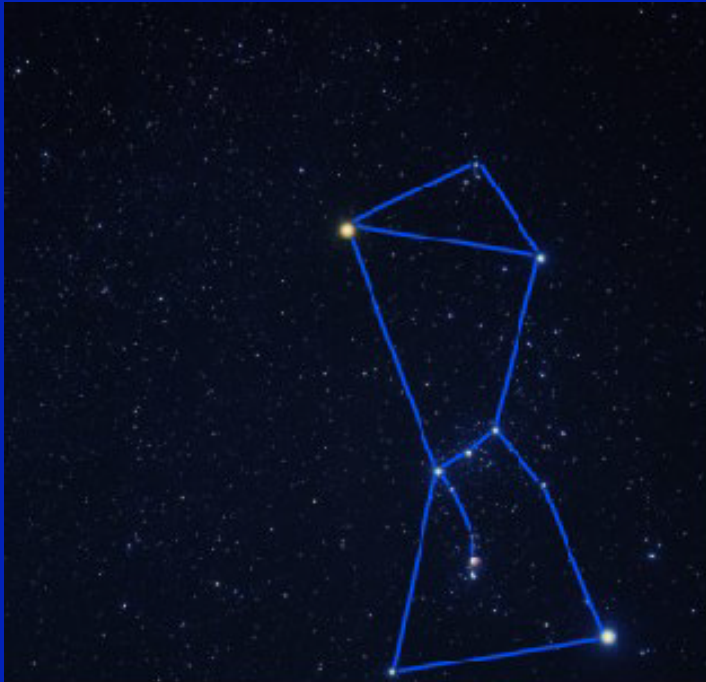

## Constellation Orion

left: view at visual wavelengths

right: far-infrared view

# Temperature determines the dominant type of radiation emitted ...

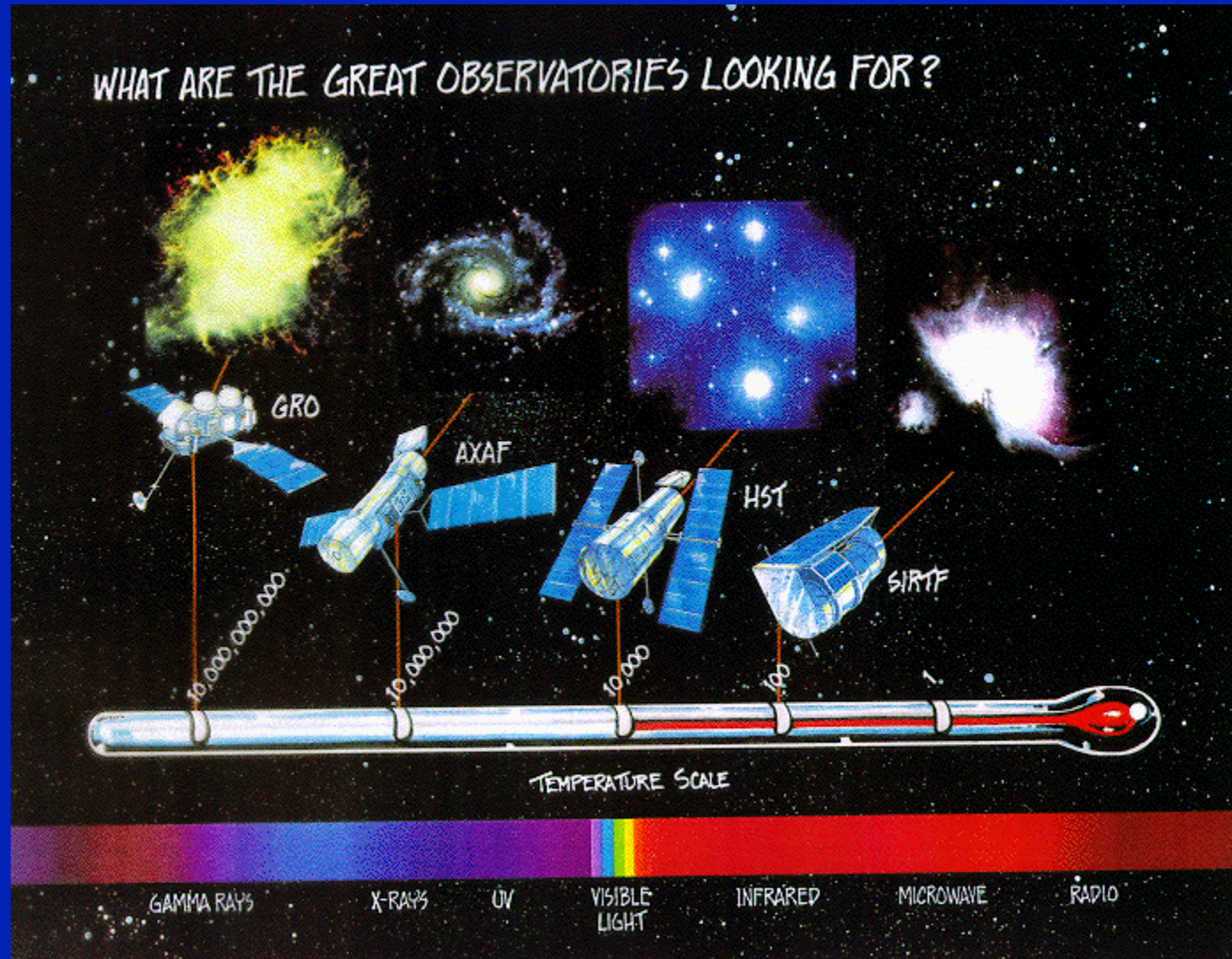

(left to right: Compton, Chandra, Hubble, and Spitzer space observatories)

# View of troposphere / stratosphere boundary (tropopause) from above





thermal-IR  
image of  
Earth from  
meteorology  
satellite



### Mauna Kea

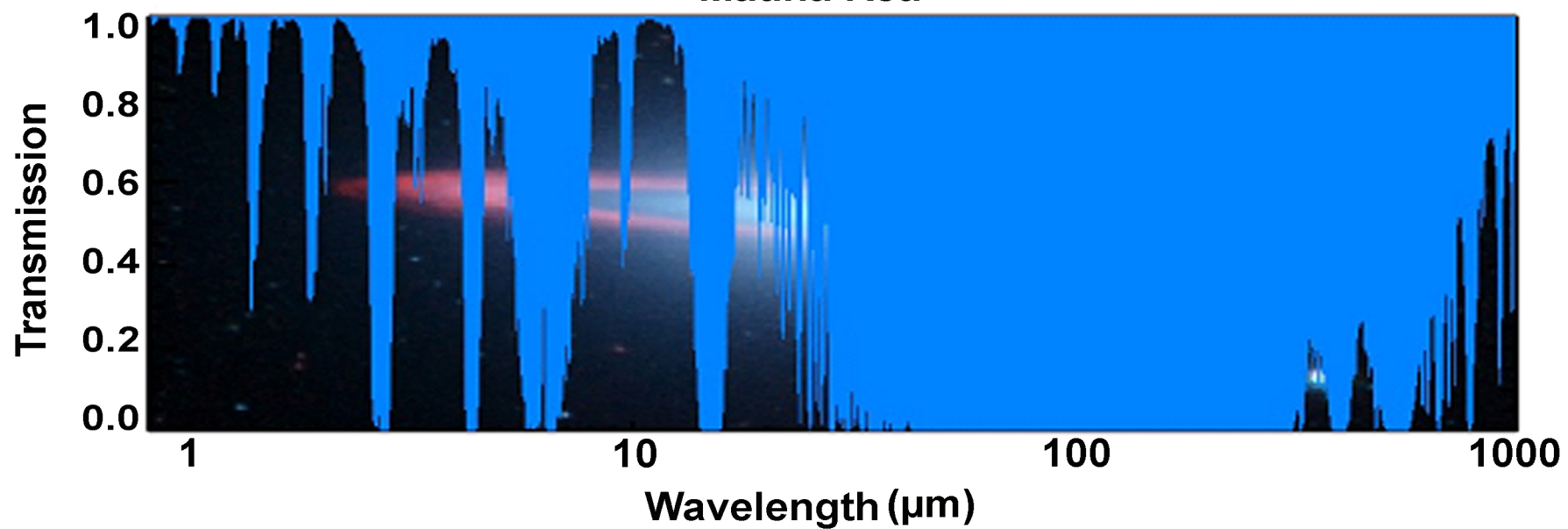

### SOFIA

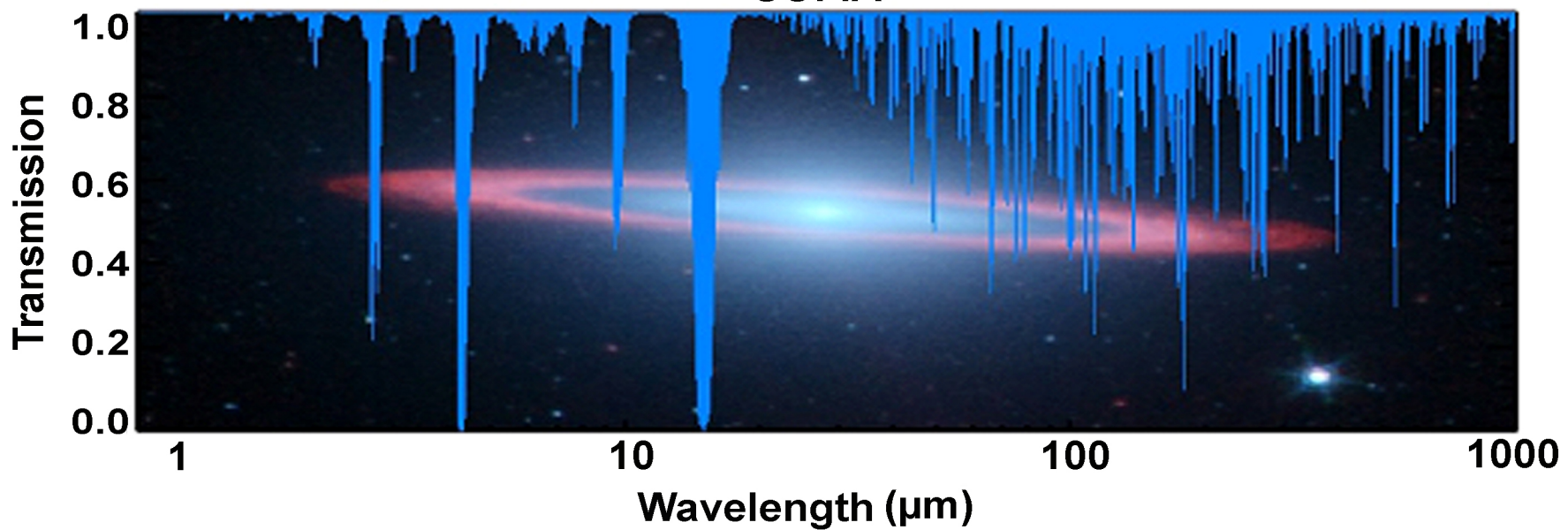

# **SOFIA--The Next Generation Airborne Observatory**

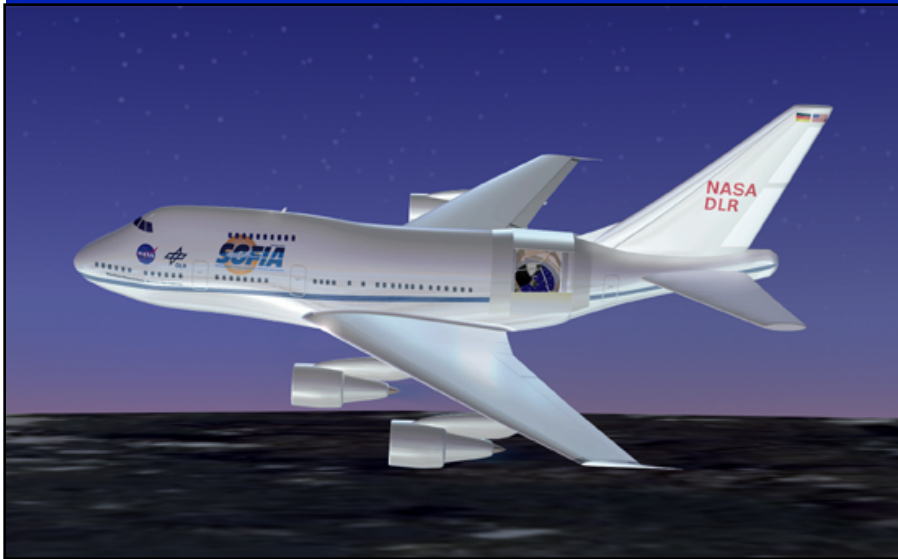

- **2.5-meter (100-inch) telescope in a Boeing 747SP**

- **Based at NASA-Dryden's Aircraft Ops Facility in Palmdale, with Science Center at NASA-Ames**

- **120+ 8-hour research flights per year; 20 year lifetime**
- **20% share with the German space agency DLR**
- **The world's largest portable telescope!**
- **Useful for both visible and infrared research**
- **1+ month per year in southern hemisphere**
- **First test flights in 2007, first science flights in 2010**

# SOFIA — The Observatory

Educator work stations

open cavity  
(door not shown)

pressure bulkhead

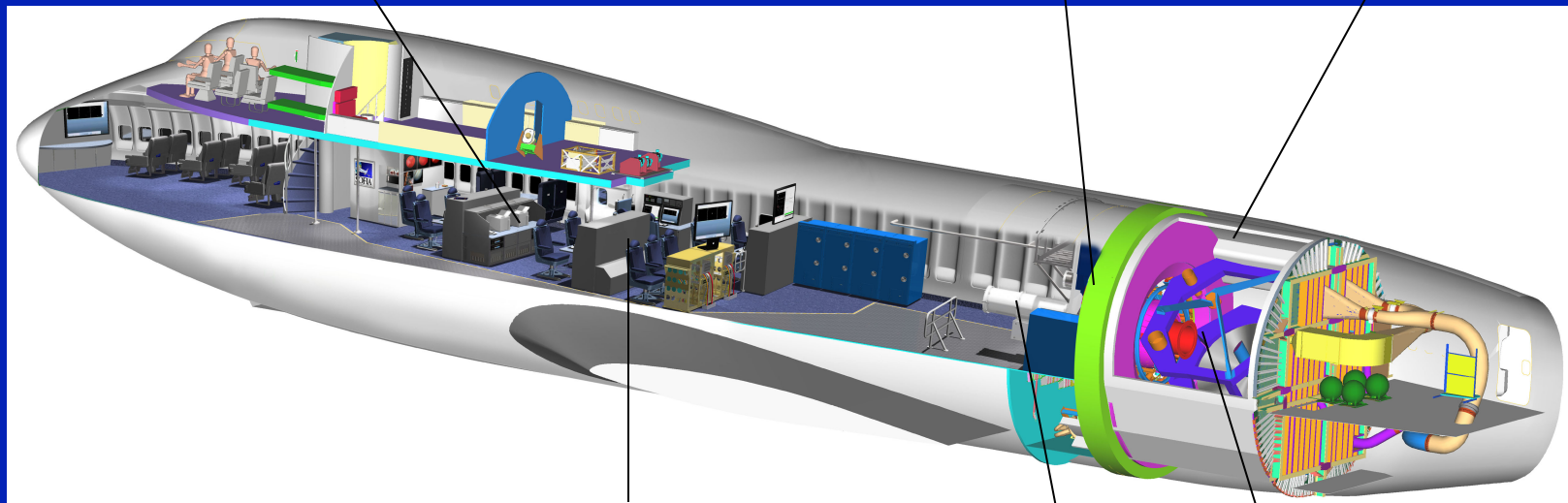

Scientist work stations,  
telescope and instrument  
control, etc.

TELESCOPE

scientific instrument (1 of 7)

# Movie - First Open Door Test Flight

## ONBOARD SOFIA

View aft from Principal Investigator console; FORCAST mid-IR camera installed



# *SOFIA Light Path*

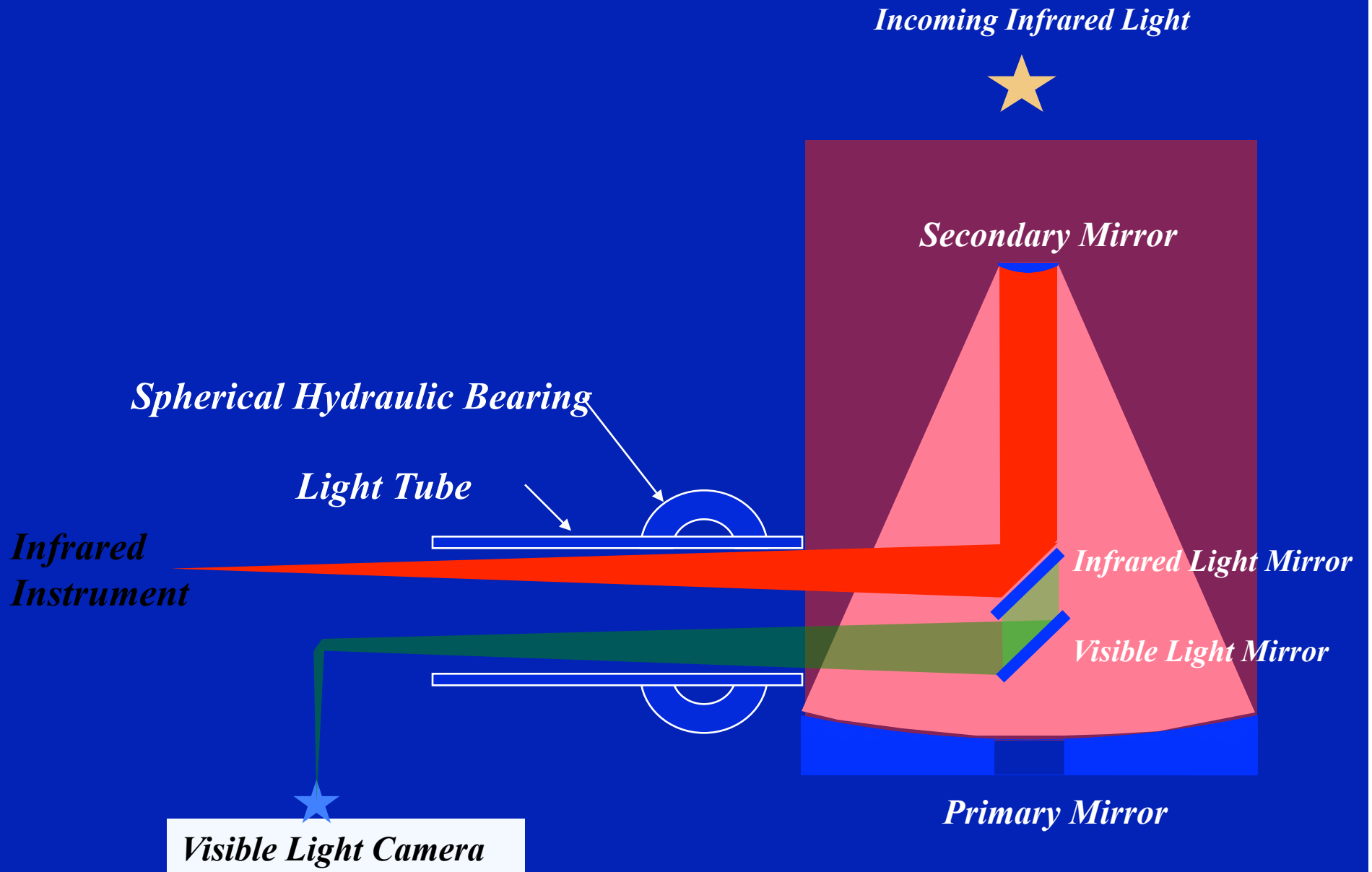

## SOFIA's primary mirror in coating tank



DIFFRACTION: limit to SOFIA's angular resolution at  $\lambda > 15 \mu\text{m}$

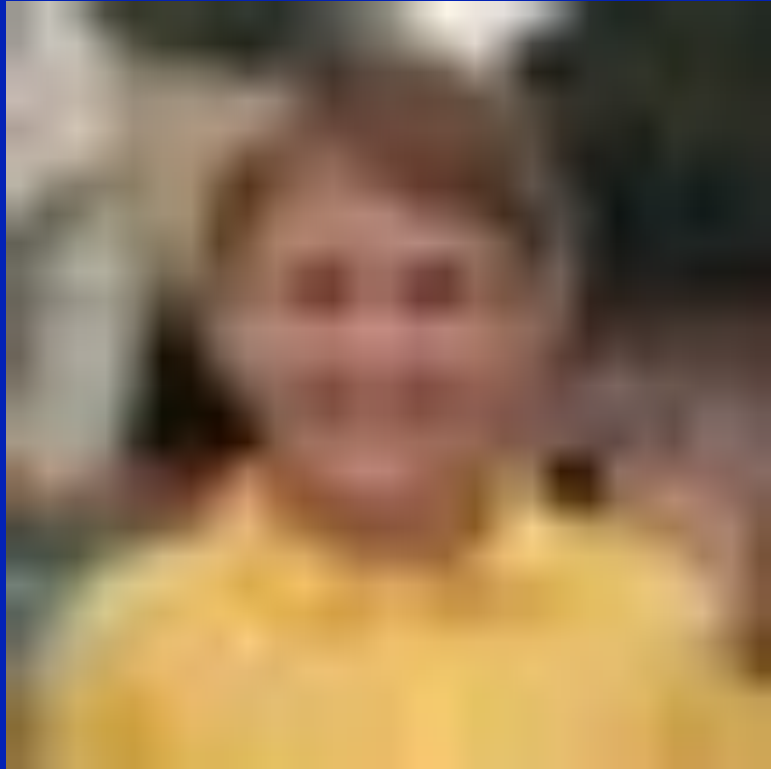

Representing the resolution of a 90-cm (36-inch) telescope



... versus a 250 cm (100-inch) telescope



**The telescope:  
Floating on spherical bearing;  
Orientation/position sensed by gyroscopes/GPS;  
Optical TV cameras view field around target**

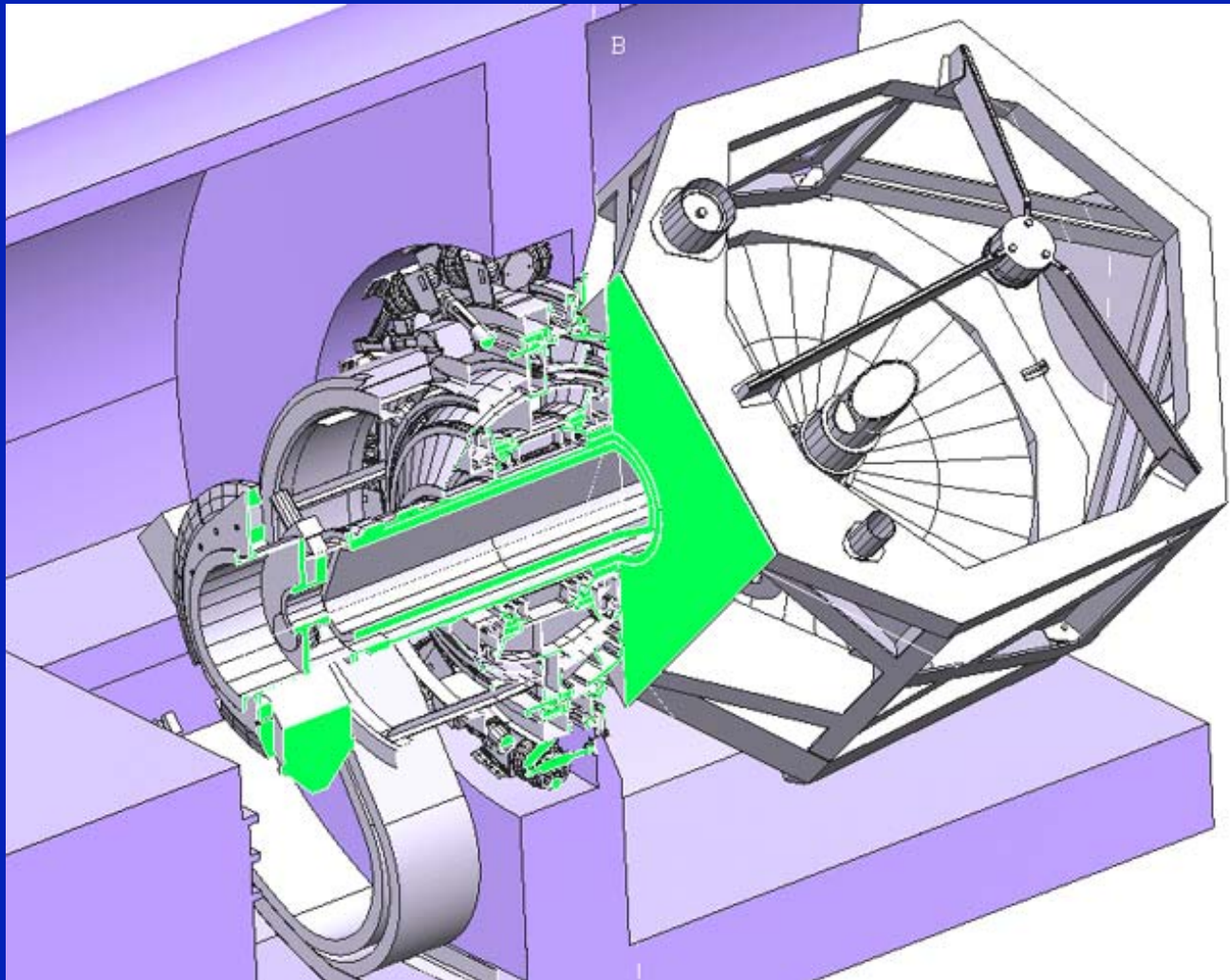

# Aero-acoustics (1)

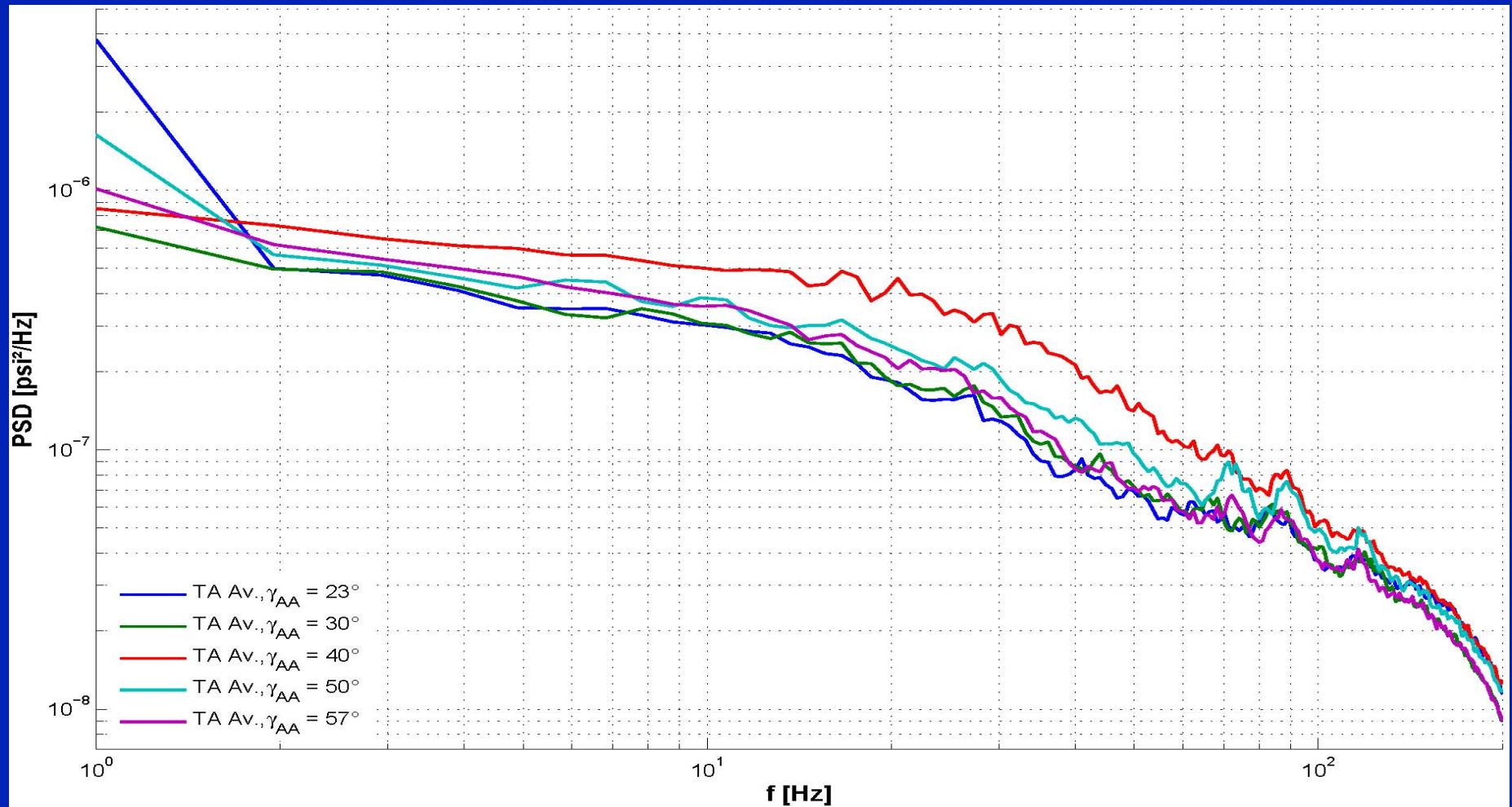

**Acoustic Power Spectrum Density (PSD) versus frequency**

# Telescope Pointing Stability

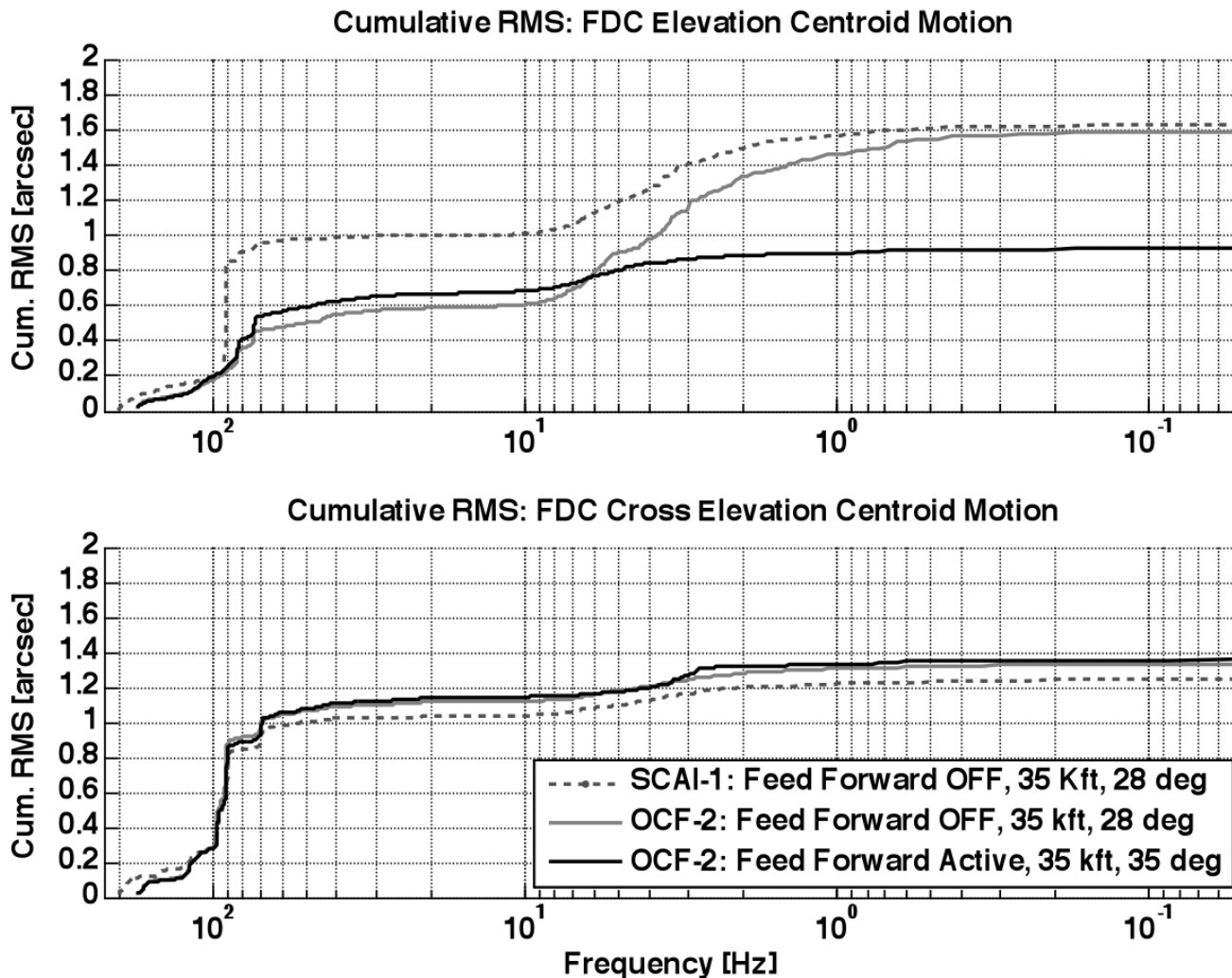

# Image Quality (PSF size)

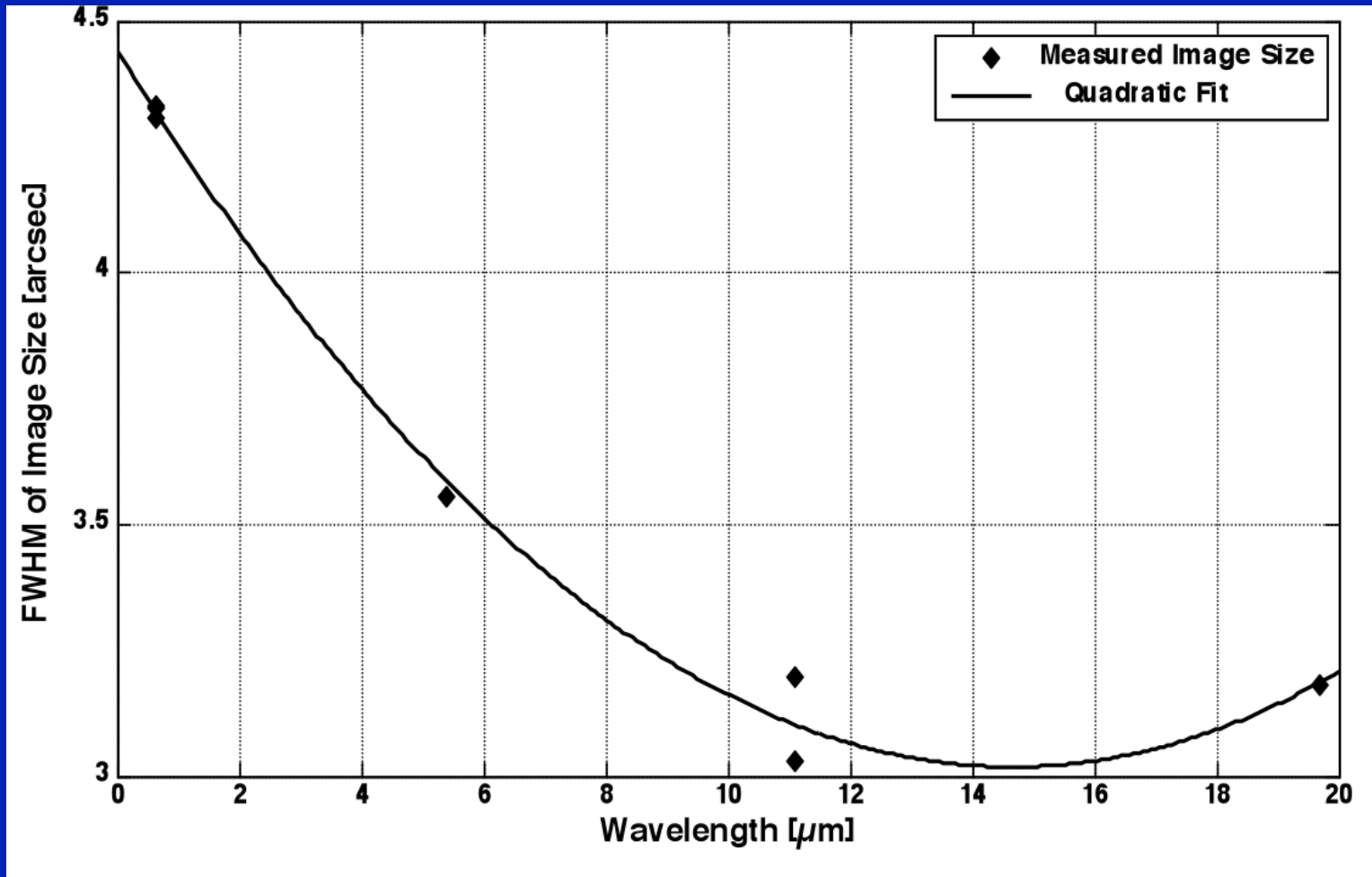

Point source image size in focal plane versus wavelength

# SOFIA's advantages & capabilities



# SOFIA's Advantages

What does SOFIA do that the Hubble Space Telescope can't?

- ◆ SOFIA can easily study:
  - > IR: objects much cooler than normal stars like the Sun  
for example: stars and planets in the process of forming;
  - > IR: objects embedded in, or behind, opaque ISM dust clouds;  
SOFIA's instruments can see into and through those clouds
  - > IR: organic molecules in space, which have many of their spectral lines and bands at infrared wavelengths;
  - > Mobility: Foreground solar system objects as they occult background stars.

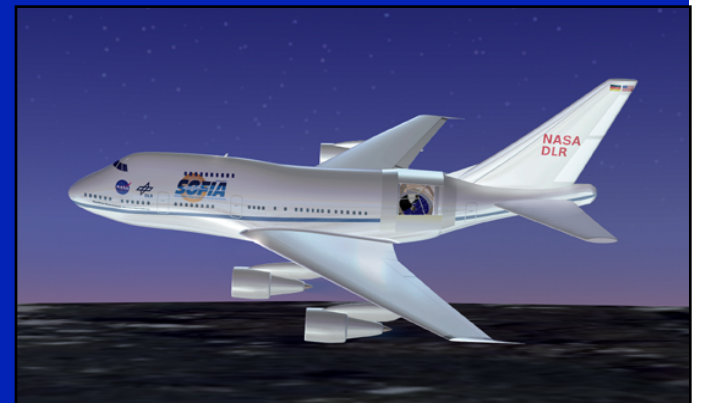

## SOFIA's advantages, cont'

---

**What does SOFIA add to what the Spitzer infrared space telescope was able to do?**

- ◆ SOFIA's telescope mirror is 3x larger than Spitzer's, so
  - > SOFIA can see details 3x smaller
  - > SOFIA can resolve objects in 9x more crowded regions
- ◆ SOFIA has more instruments than Spitzer (7 versus 3), so:
  - > SOFIA has more ways to analyze a wider range of wavelengths
  - > SOFIA will have 2<sup>nd</sup>-, 3<sup>rd</sup>- and 4<sup>th</sup>-generation instruments
- ◆ SOFIA has a design lifetime of 20 years, versus Spitzer's 5 years (limited by cryogen supply)

# SOFIA's First-generation Scientific Instruments

The 7 first-generation instruments cover the full IR range with imagers and low-to-high resolution spectrographs

(<http://www.sofia.usra.edu/Science/instruments/>)

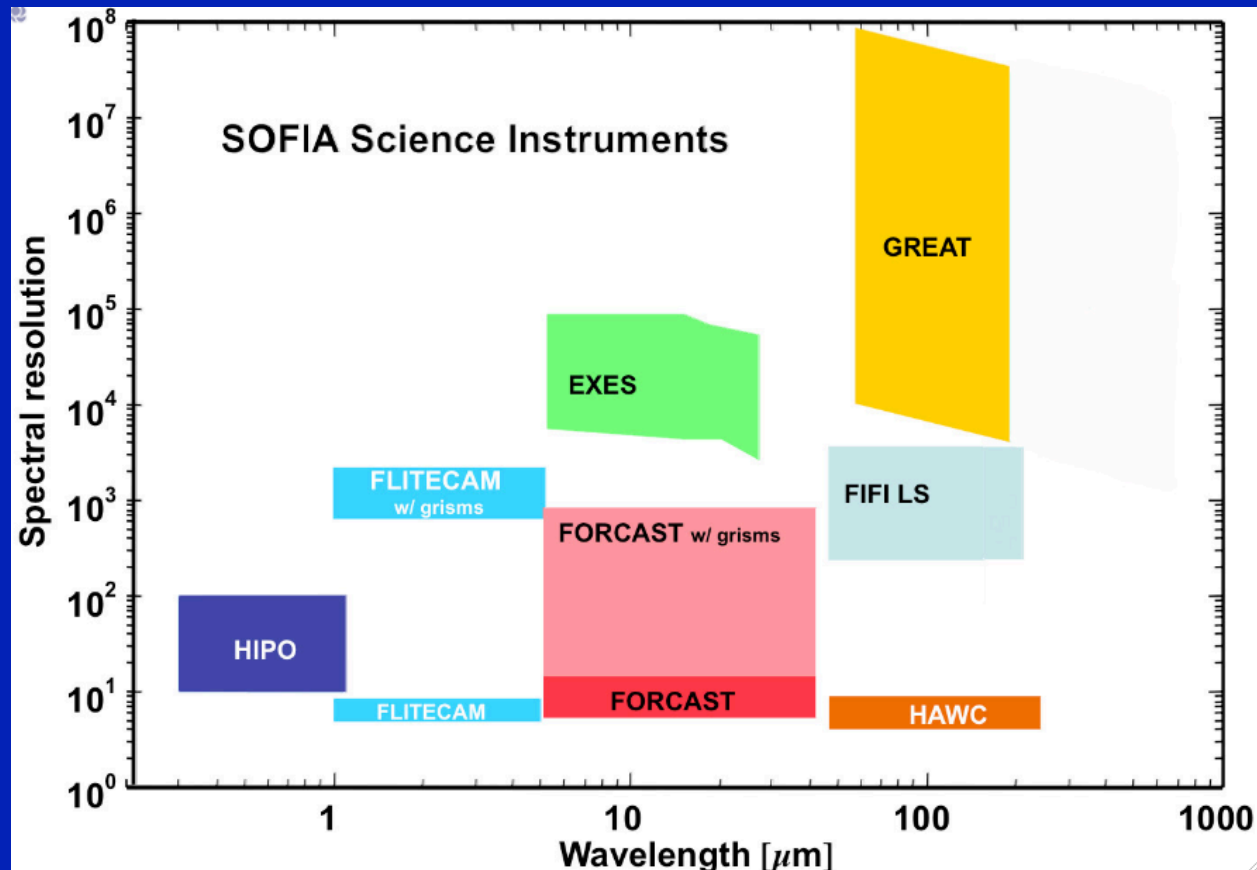



# *First four instruments ...*



**FORCAST**  
mid-IR  
camera  
(Cornell)

**GREAT**  
far-IR  
heterodyne  
spectrometer  
(MPIfR)

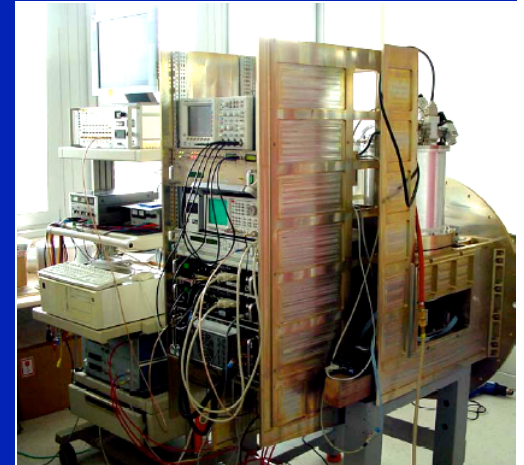

Lab-picture of GREAT equipped with the  
KOSMA 1.9THz channel

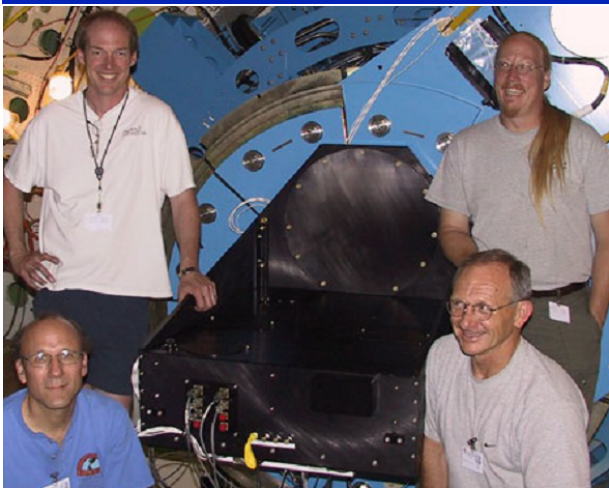

**HIPO**  
optical  
high-speed  
photometer  
(Lowell  
Observatory)

**FLITECAM**  
near-IR  
camera  
(UCLA)

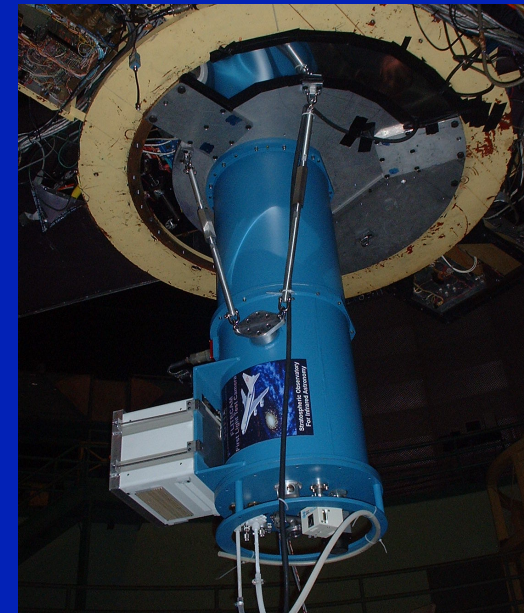

# SOFIA's Scientific Instruments

- ◆ FORCAST (camera; Cornell) 2010
- ◆ GREAT (spectrometer; Germany) 2011
- ◆ HIPO (photometer; Lowell Obs.) 2011
- ◆ FLITECAM (camera; UCLA) 2011
- ◆ FIFI LS (spectrometer; Germany) 2012
- ◆ HAWC (camera; U. Chicago) 2012
- ◆ EXES (spectrometer; Ames/UC-Davis) 2013

## ◆ Star and Planet Formation

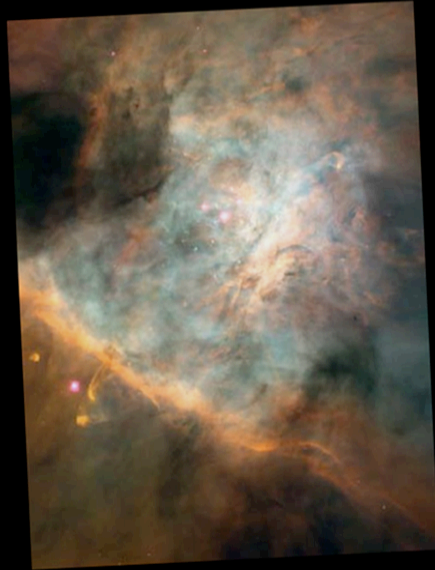

visible light (HST)



near-infrared (ESO)

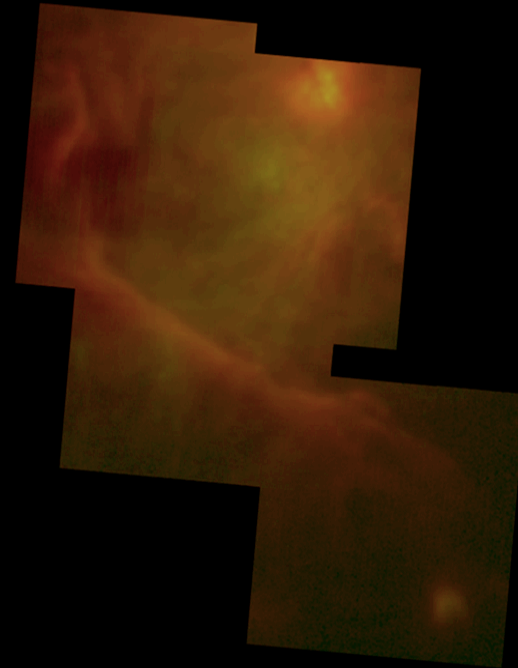

mid-infrared (SOFIA)



SOFIA mid-IR image of  
Orion Messier 42  
star-forming region

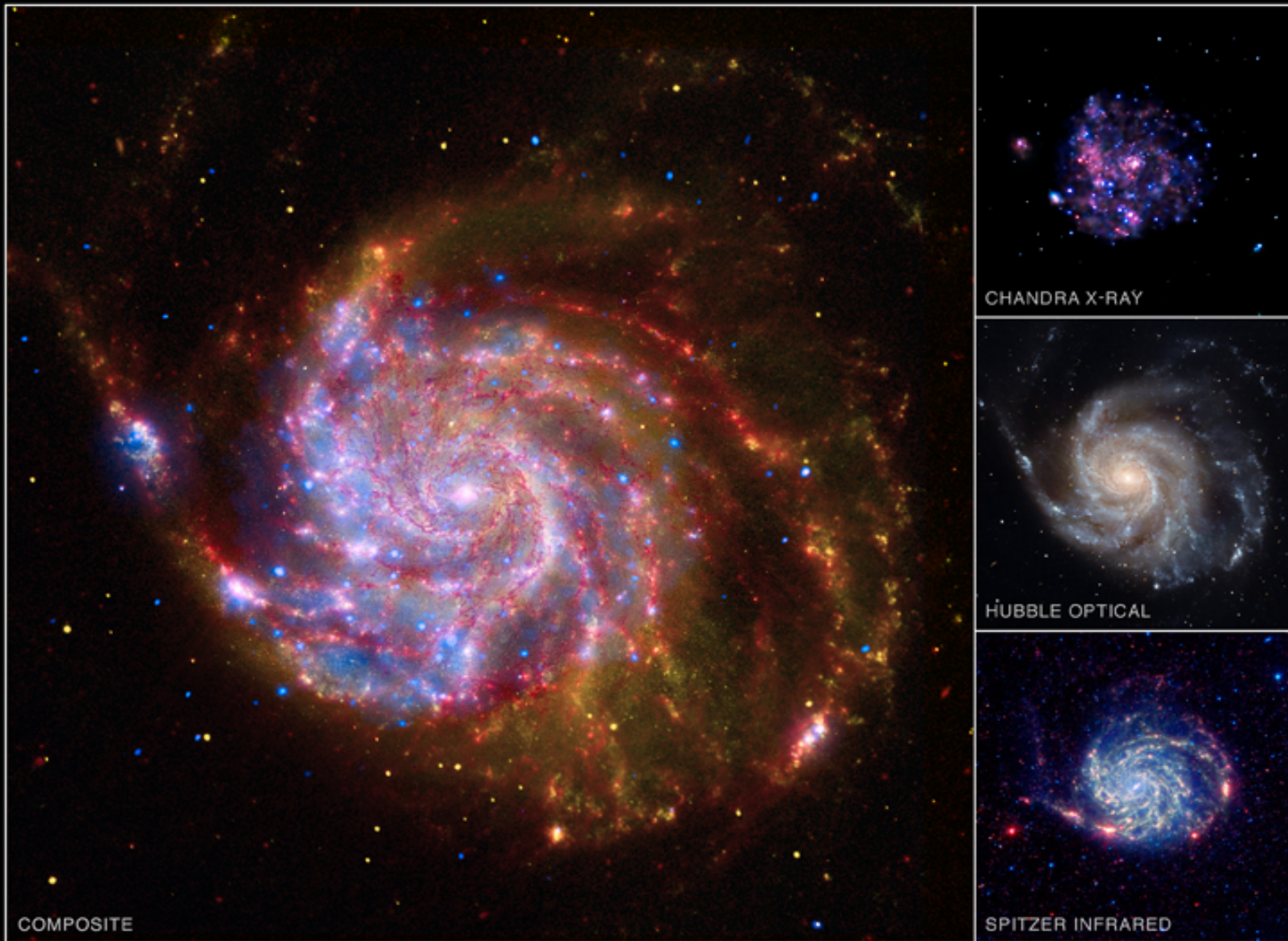

**Messier 101 -- The “Pinwheel” Galaxy**

# The Milky Way Galaxy's Center

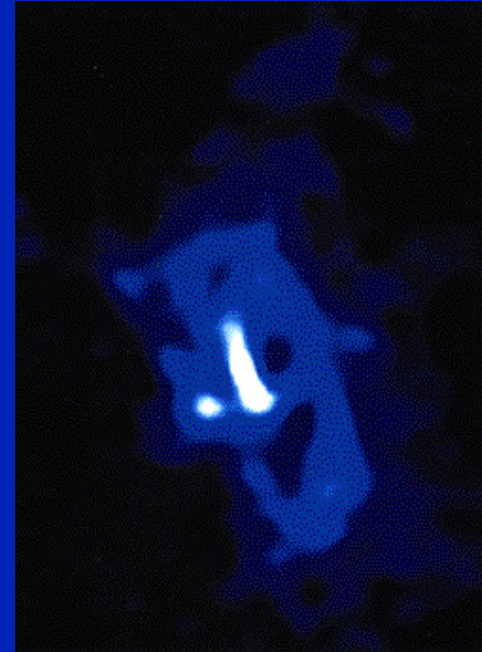
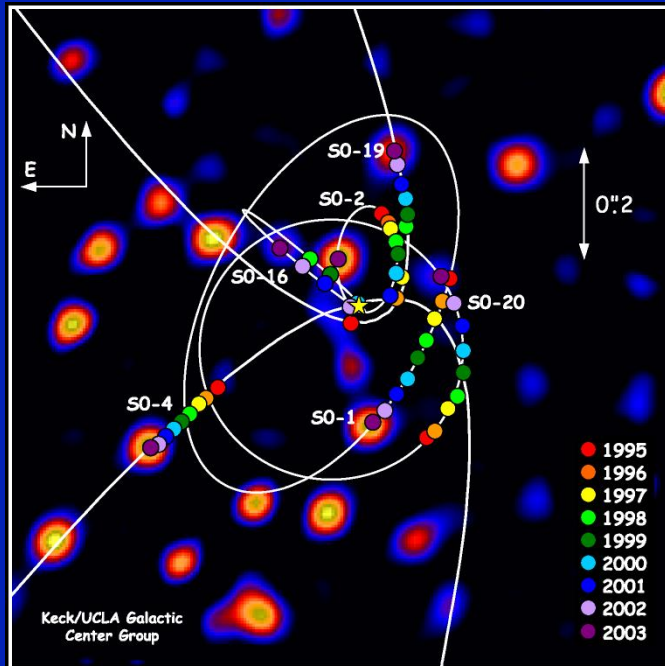

- \* SOFIA's angular and spectral resolution will allow discernment of:
  - How much material is fed into the central black hole and much gravitational potential energy is released thereby
  - Characteristics of the resulting variable infrared source
  - How our galaxy compares with other galaxies hosting active nuclei

# “Starburst” galaxy Messier 82

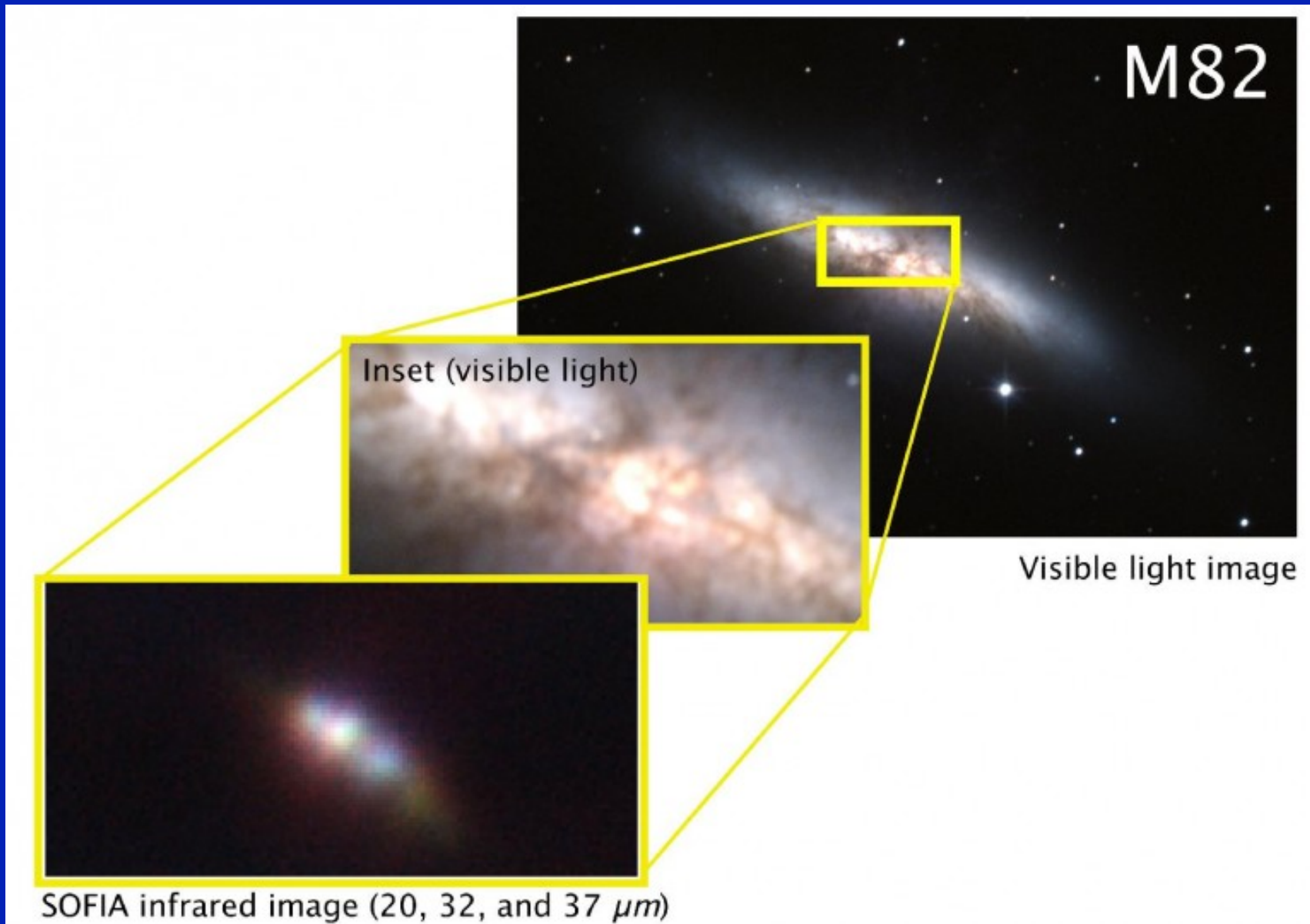

# ◆ Interstellar Chemistry and Organic Molecules



# ORGANIC MOLECULES IN SOLAR SYSTEM OBJECTS



Murchison  
meteorite

© 2006 Brooks/Cole - Thomson

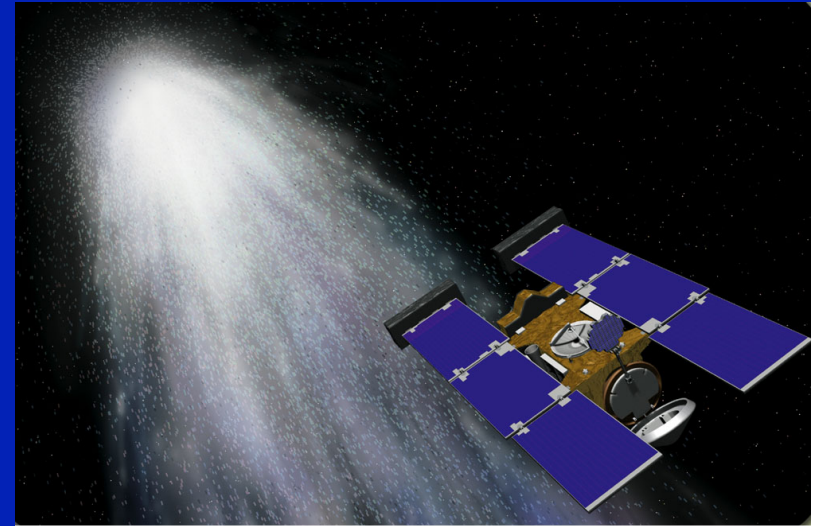

Comet  
Wild 2

© 2006 Brooks/Cole - Thomson

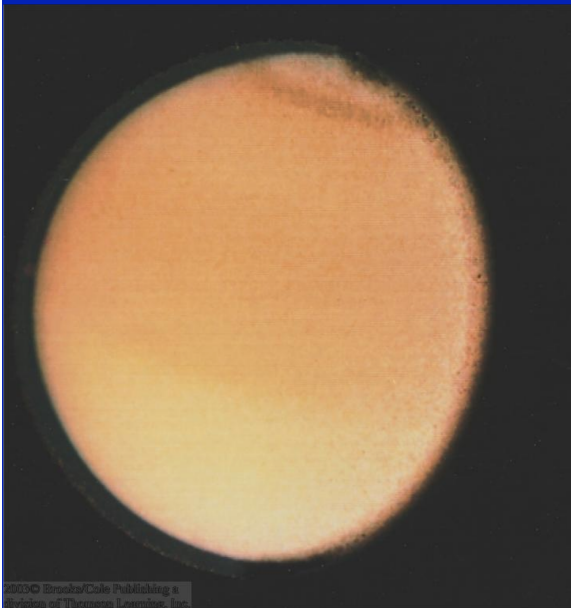

Saturn's  
moon  
Titan

© 2003 Brooks/Cole Publishing a  
division of Thomson Learning, Inc.

Saturn's  
moon  
Enceladus





Eagle Nebula  
(Messier 19)  
“Pillars of  
Creation”  
star-forming  
region –  
brown dust is  
partly organic  
substances.



Red-brown  
color  
represents  
organic  
molecules  
in galaxy  
Messier 81's  
star-forming  
clouds

**Spiral Galaxy M81**

**Spitzer Space Telescope • IRAC**

NASA / JPL-Caltech / S. Willner (Harvard-Smithsonian CfA)

trc2003-08c

# Organic Growth & Chemistry in Space

## Formation

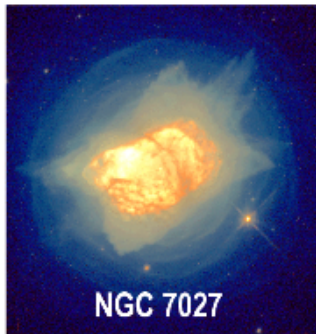

**A** Stellar Outflows

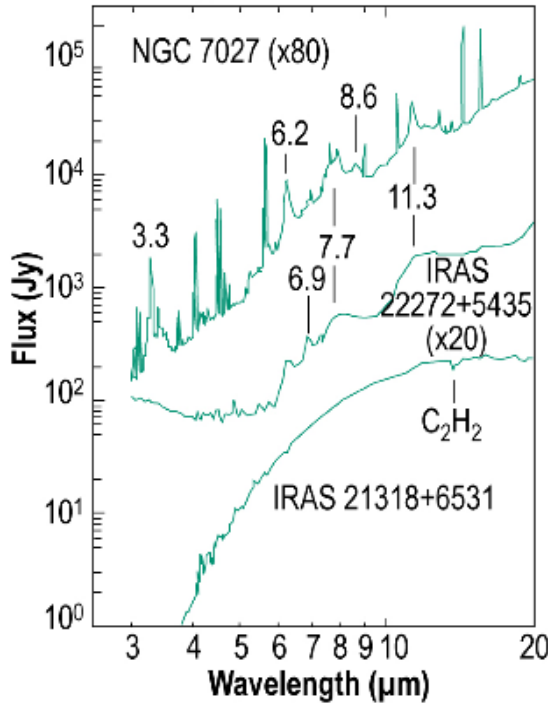

## Processing



**C** Dense ISM

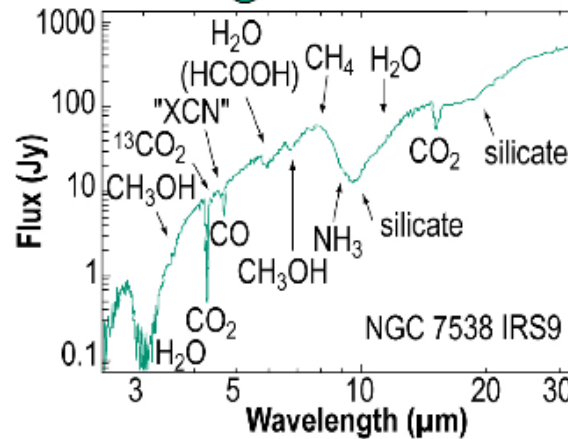

## Fossil / Delivery



**D** Solar System

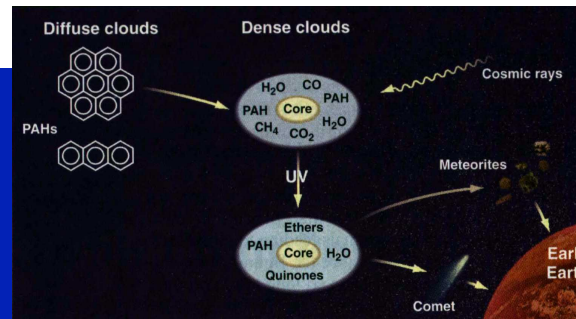
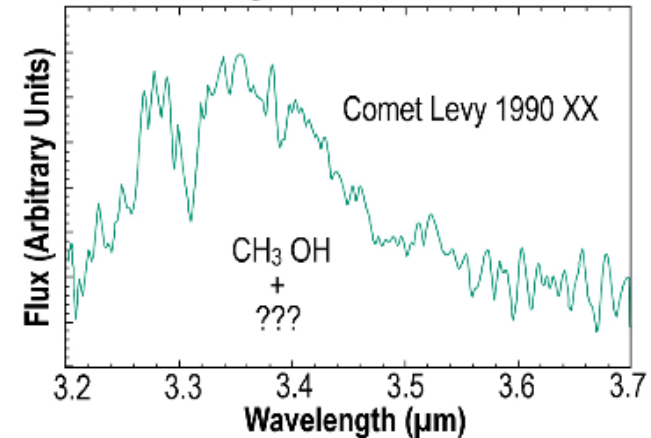

# ◆ Planets and Planetary Evolution

SOFIA infrared image  
(5.4, 24, and 37  $\mu\text{m}$ )



Visible light image

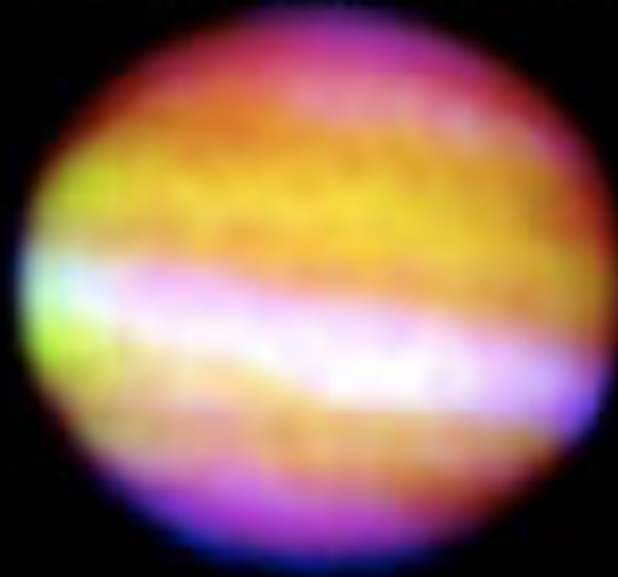

SOFIA's  
"First Light"  
Image of Jupiter  
May, 2010



VENUS – did it once have oceans? Need further spectroscopy (esp D/H ratio) and modeling of atmospheric chemistry.

# Methane in the Martian Atmosphere

- Methane gas was recently detected in Mars's atmosphere using ground-based telescopes.
- The methane gas distribution is patchy and changes with time.
- Most methane in Earth's atmosphere is produced by life, raising questions about its origin on Mars.

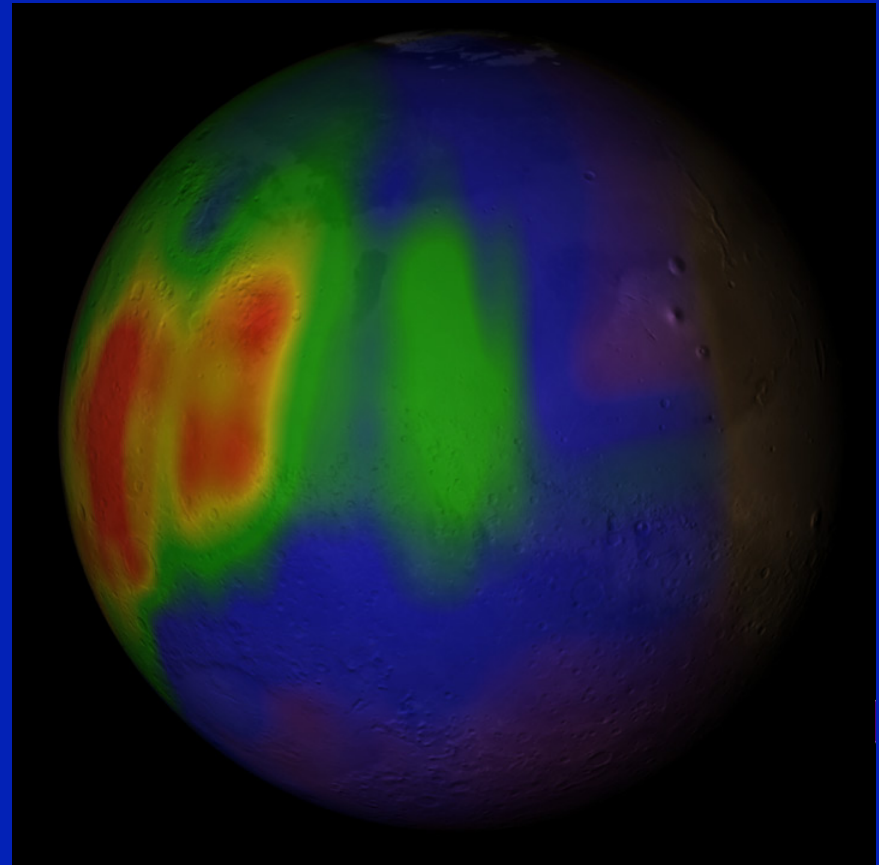

*View of Mars colored according to the methane concentration observed in the atmosphere. Warm colors depict high concentrations.*



# Planetary Science; Occultations

## SOFIA is able to:

- ❖ Go anywhere on Earth to reach the occultation shadow of an object
- ❖ Can probe the sizes, structures (rings & moons), and atmospheres of solar system bodies by measuring how they occult background stars
- ❖ This will be the primary objective for HIPO (High-speed Imaging Photometer for Occultations)

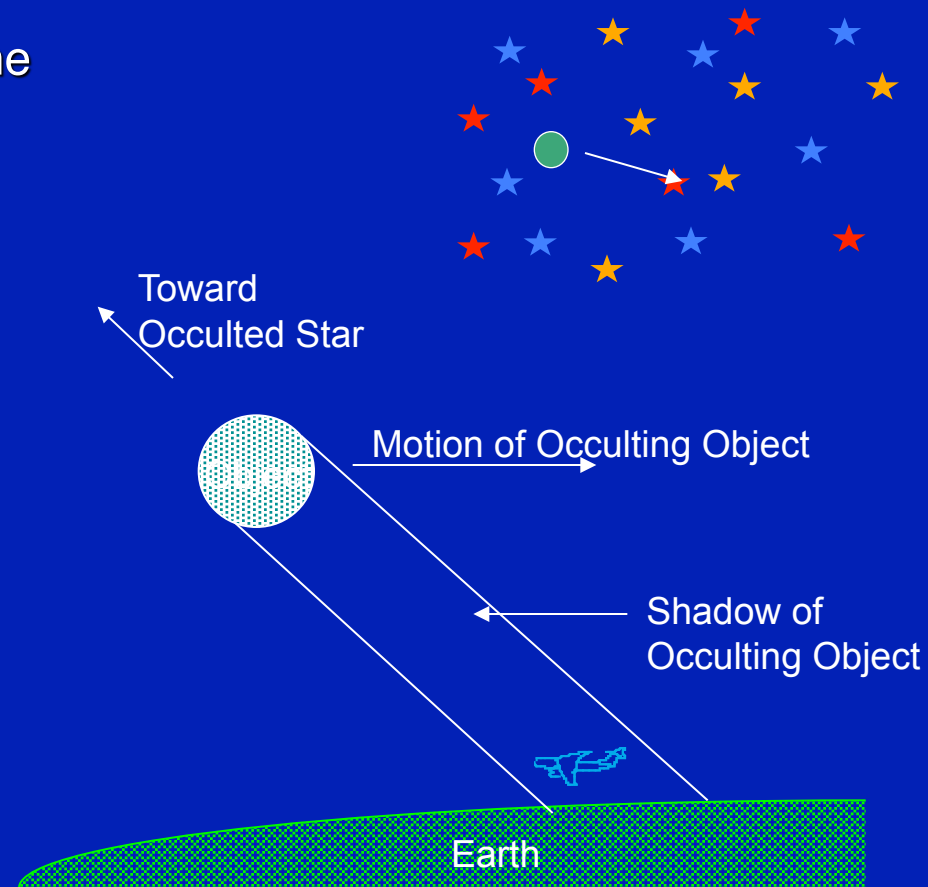

# SOFIA observations of a stellar occultation by Pluto on July 23, 2011

- Dwarf planet Pluto ( $V \sim 14$ ) occulted a star ( $V \sim 14.4$ ).
- SOFIA met the shadow of Pluto in mid-Pacific.  $\Rightarrow$
- HIPO (Lowell Obs.) and FDC (DSI) instruments observed the occultation simultaneously.



## Image sequence from the Fast Diagnostic Camera (FDC)

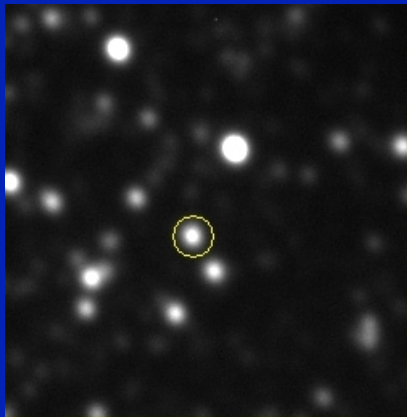

Pluto (circled) is 13 arcsec from the star 200 minutes before the occultation

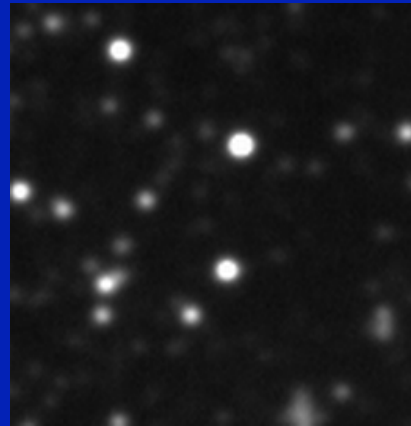

Just before occultation: Pluto and star merged, combined light

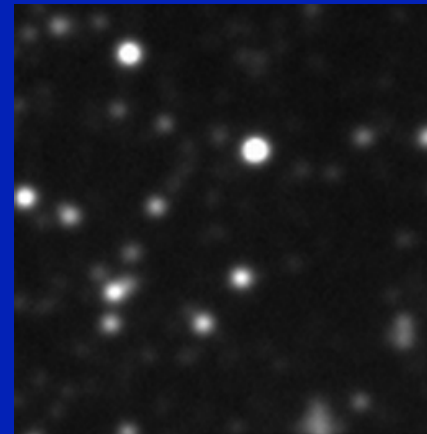

During occultation: Pluto and star merged, only Pluto light seen

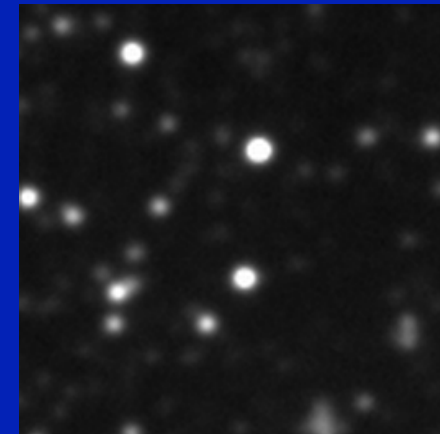

After occultation: Pluto and star merged, combined light

# SOFIA's E&PO Programs: Airborne Astronomy Ambassadors



# SOFIA Outreach Responsibilities

## Education

- FLAGSHIP PROGRAM: research flight experience for educators
- \* Summer workshops for college faculty and undergraduates to encourage research
- Production of classroom activities & curricula; school visits; teacher workshops
- Exhibits in science museums and similar venues (e.g. Ames Visitors Center)

## Public Outreach

- SOFIA program website content, printed materials & “new media” presence
- Displays at public events (e.g. air shows, street fairs)
- Contacts with local government bodies, representatives, & civic groups

## Public Affairs

- News releases and media productions regarding SOFIA achievements
- Support for media science coverage (e.g. magazine articles, NOVA programs)
- Long-term relationships with media & journalists
- Support for SOFIA personnel in news media interviews

## Science Outreach (shared responsibility)

- SOFIA exhibits, talks, posters and PR materials at scientific conferences
- Support for talks, posters and papers by SOFIA scientists and engineers
- Role in definition and management of Early Science program

# Educators Participate in SOFIA Science Flights as Airborne Astronomy Ambassadors



- On May 10, NASA announced the selection of six educators from across the U.S. to serve as the first class of SOFIA Airborne Astronomy Ambassadors (AAAs).
- The AAA program is SOFIA's flagship E/PO program. Throughout SOFIA's 20 years of operations, as many as 60 educators per year will be selected by peer review of proposals. The Ambassadors will fly and work on SOFIA as partners to teams of astronomers.
- AAAs have developed specific plans for using their SOFIA experiences to inform their teaching, in addition to sharing their knowledge with other educators.
- The entire inaugural class of six U.S. and two German AAAs has now flown on SOFIA.

## For further information:

- ◆ SOFIA Science Center home page
  - <http://www.sofia.usra.edu>  
(includes notice & link for AAA applications -- due 11/15)
- ◆ Spitzer Space Telescope's award-winning infrared tutorial
  - <http://coolcosmos.ipac.caltech.edu>  
(includes instructions for home-made Herschel demo)
- ◆ To contact the presenter:
  - [dbackman@sofia.usra.edu](mailto:dbackman@sofia.usra.edu)