

Interface Control Document

SI Equipment Rack / TA Counterweight Interface

TA_SI_05

SOF-DA-ICD-SE03-051

Date: April 18, 2011

Revision: 2



DFRC
Dryden Flight Research Center
Edwards, CA 93523

ARC
Ames Research Center
Moffett Field, CA 94035



German Space Agency, DLR
Deutsches Zentrum für Luft
und Raumfahrt

VERIFY THAT THIS IS THE CORRECT VERSION BEFORE USE

Interface Control Document
SI Equipment Rack / TA Counterweight Interface
TA_SI_05

PREPARED BY:



Daniel Kozarsky / ARC / Science Project SE&I Lead
Date 4/28/11

CONCURRENCE:



Scott Horner / ARC / Science Project Science Instrument Manager
Date 28 April 2011



Gelsomina Cappuccio / ARC / Science Project Manager
Date 4/28/11



Eric Becker / DFRC / Aircraft Operations Manager
Date 4/28/2011



Brent Cobleigh / DFRC / Airborne Platform Project Manager
Date 5/2/11



Stephen Jensen / DFRC / Program Chief Engineer
Date 4/28/2011

Thomas Keilig / DSI / Platform Project Telescope Assembly Manager
Date

APPROVALS:



Robert Meyer / DFRC / SOFIA Program Manager
Date 5/3/11

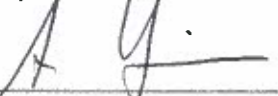

Alois Himmes / DFRC / SOFIA DLR Program Manager
Date 05/09/11

VERIFY THAT THIS IS THE CORRECT VERSION BEFORE USE

Interface Control Document SI Equipment Rack / TA Counterweight Interface TA_SI_05

PREPARED BY:

Daniel Kozarsky / ARC / Science Project SE&I Lead

Date

CONCURRENCE:

Scott Horner / ARC / Science Project Science Instrument Manager

Date

Gelsomina Cappuccio / ARC / Science Project Manager

Date



Eric Becker / DFRC / Aircraft Operations Manager

Date

4/28/2011

Brent Cobligh / DFRC / Airborne Platform Project Manager

Date



Stephen Jensen / DFRC / Program Chief Engineer

Date

4/28/2011

For 
Thomas Keilig / DSI / Platform Project Telescope Assembly Manager
Unich Computer, PSI

Thomas Keilig / DSI / Platform Project Telescope Assembly Manager

Date

5/3/2011

APPROVALS:



Robert Meyer / DFRC / SOFIA Program Manager

Date

5/3/11

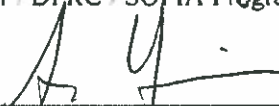

Alois Himmes / DFRC / SOFIA DLR Program Manager

Date

05/09/11

VERIFY THAT THIS IS THE CORRECT VERSION BEFORE USE

Revision History

REV	DATE	DESCRIPTION	APPROVAL
1	2/8/2010	Based on Initial NASA SPO release of USRA Final ICD TA_SI_05_FL, Revision 0, Dated 6 March 2002. (RAIS Document Number: 96145560-000, USRA DR: SE03-051). The CWR/CWP electrical isolation material was changed from G-10 fiberglass to Nylon 66 MoS2 in Figure 3.1-5. A design change in the CWR alignment dowel pins is reflected in Figure 3.1-7.	PMB
2	4/18/2011	Updated reference document list. Added information about items classified as SI payload and items included in CWR installation. Revised grounding requirement for CWR structure. Revised allowable SI payload weight range per a classification change of Electronic Interface Channels from part of the CWR structure to SI payload. Corrected metric value for diameter of dowel pin. Moved populated CWR C.G. requirement to ICD SI_CWR_01.	PMB

VERIFY THAT THIS IS THE CORRECT VERSION BEFORE USE

TABLE OF CONTENTS

PARAGRAPH	TITLE	PAGE
1.0	SCOPE	1
1.1	PURPOSE	1
1.2	CONTRACTOR RESPONSIBILITIES	1
2.0	APPLICABLE DOCUMENTS	2
2.1	ORDER OF PRECEDENCE	2
2.2	REQUIRED DOCUMENTS	2
2.3	OTHER RELATED DOCUMENTS	2
3.0	INTERFACE REQUIREMENTS	3
3.1	PHYSICAL	3
3.2	FUNCTIONAL	13
3.2.1	<i>Electrical</i>	13
3.2.2	<i>Hydraulic and Pneumatic</i>	13
3.3	ENVIRONMENTAL	13
3.3.1	<i>Interface Loads</i>	13
3.3.2	<i>Vibration Isolation</i>	13
3.3.3	<i>Heat Dissipation</i>	14
3.4	SAFETY	14
4.0	QUALITY ASSURANCE PROVISIONS	14
5.0	DEFINITIONS, ABBREVIATIONS, ACRONYMS	14
6.0	NOTES	14

VERIFY THAT THIS IS THE CORRECT VERSION BEFORE USE

LIST OF ILLUSTRATIONS

FIGURES	TITLE	PAGE
Figure 3.1-1	Location of counterweight rack (CWR) on counterweight plate (CWP)	5
Figure 3.1-2	Counterweight rack (CWR) Installation.	6
Figure 3.1-3	Detail of attachment locations for CWR to CWP.....	7
Figure 3.1-4	CWR alignment dowel pin locations showing CWR orientation with TA at 40° position.	8
Figure 3.1-5	Counterweight rack (CWR) attachment and electrical isolation concept.....	9
Figure 3.1-6	CWP Strut Attachment bracket.....	10
Figure 3.1-7	CWR alignment dowel pins.....	11
Figure 3.1-8	Alignment Pin Electrical Isolation.....	12

VERIFY THAT THIS IS THE CORRECT VERSION BEFORE USE

1.0 Scope

The scope of this document is to define the physical, functional, environmental, and safety related interface requirements between the TA Counterweight Plate (CWP) and Science Instrument Equipment Rack also known as the Counterweight Rack (CWR). It also addresses contractor responsibilities for interface parts provisioning as well as CWR installation services in the SOFIA aircraft.

1.1 Purpose

The purpose of this ICD is to define the interface requirements and any accompanying design constraints for a Science Instrument Equipment Rack also known as the Counterweight Rack (CWR) that will mount on the forward side of the Counterweight Plate (CWP). Interface requirements include the following:

Physical requirements

- The locations and method of attachment of the CWR to the CWP.
- The locations and method of attachment of alignment pins to facilitate CWR installation on CWP.
- The locations and methods of attachment of strut fittings to CWP and support struts to strut fittings.
- The allowable CG envelope and mass of a fully loaded CWR.
- The allowable envelope dimensions for an installed CWR.
- Locations of through holes for the routing and strain relief of cables from the CWR to the SI and from the SI Patch panel to the CWR.

Functional requirements

- Power supply and data transmission cables
- Electrical isolation provisions, CWR from TA
- Electrical ground provisions, CWR to TA
- Hydraulic and pneumatic supply lines

Environmental requirements

- Interface loads
- Vibration isolation from mounted equipment
- Heat dissipation from mounted electrical/electronic equipment

1.2 Contractor Responsibilities

Counterweight Racks will be made available to SI teams through USRA.

USRA Ground Operations will be responsible for providing CWR interfacing hardware and CWR installation services in the SOFIA aircraft.

VERIFY THAT THIS IS THE CORRECT VERSION BEFORE USE

2.0 Applicable Documents

The data referenced in this ICD represents the latest version at the time of issuance of this ICD, unless otherwise stated, and forms a part of these requirements to the extent specified herein.

2.1 Order of Precedence

In the event of a conflict between the text of this ICD and the references cited herein, the text of this ICD takes precedence. Nothing in this ICD, however, supersedes contractual requirements unless a specific exemption has been obtained and approved. As appropriate, reference is made to other project documentation for use as guidance in developing the content of this ICD and as such forms a basis for requirements to the extent specified herein.

2.2 Required Documents

SOF-1011, Rev. 6	TA Requirements Document
DCR-0148	Document Change Request to change SOF-1011 SI c.g. & Mass Change Accommodation
SOF-1030, Rev. 3	Systems Interface Requirements
DCR-0012 Rev. 5	Document Change Request for SOF-1030 to Clarify Performance and Airworthiness Loads

2.3 Other Related Documents

PD-2009	SOFIA Lexicon
SCI-AR-ICD-SE03-2027	ICD SI_CWR_01, Science Instrument Equipment to Counterweight Rack ICD
SOF-DF-ICD-SE03-013	ICD TA_AS_03, Aircraft System/Telescope Assembly Cable Load Alleviator Device Interface
SOF-DA-ICD-SE03-036	ICD TA_SI_01, Telescope Assembly/Cable Load Alleviator/Science Instrument Cable Interface
SOF-DA-ICD-SE03-037	ICD TA_SI_02, Telescope Assembly/Science Instrument Mounting Interface
SOF-DA-ICD-SE03-045	ICD GLOBAL_05, SOFIA Coordinate Systems
SOF-DA-ICD-SE03-002	ICD GLOBAL_09, Science Instrument Envelope
SOF-DF-ICD-SE03-010	ICD TA_AS_04, Aircraft System/TA Installation and Removal Interface Requirements
SSMOC-SCIN-DWG-3200.00	Counterweight Rack, Ballast Weights Assembly
SSMOC-SCIN-DWG-3200.01	Rack Ballast Weight

VERIFY THAT THIS IS THE CORRECT VERSION BEFORE USE

3.0 Interface Requirements

3.1 Physical

- (a) The counter weight rack (CWR) shall be attached to the CWP above the fine balance motors on the forward face of the CWP as depicted in Figure 3.1-1 and detailed in Figures 3.1-2 and 3.1-3. The CWP shall have a thickness of 0.400 in. (10.2 mm).
- The CWR shall be mounted prior to the science instrument (SI) installation. Figure 3.1-4 shows a view of a CWR placement with the TA at a 40° position.
- (b) The CWR mass and center of gravity shall be in accordance with the overall SI CG and mass budget as specified in Section 4.2 of SE03-037 (ICD TA_SI_02). See Items (f) and (g) below.
- (c) The CWR, excluding the 3 support struts described in Item (e) below, shall occupy an envelope which shall not exceed the following (See Figure 3.1-2):
- In u direction (fwd-aft), 24.25 inches (616 mm).
 - In v direction (side-side), 51.00 inches (1295.4 mm).
 - In w direction (up-down), 24.25 inches (616 mm).
- (d) The CWR shall be attached to the CWP at eight (8) attachment points on the CWP. The locations of the attachment points are shown in Figure 3.1-3.
- Each of the 8 CWR attachment points shall be through holes in the CWP with a diameter of 0.413 in. \pm 0.008 in. [10.5mm \pm 0.2mm].
 - Each of the 8 CWR attach fasteners will be electrically isolated as shown in Figure 3.1-5.
 - CWR-to-CWP attachment hardware as follows:
 - NAS6304U17 Bolt (CRES)
 - SCI-AR-DWG-SE02-2084 Washer (CRES)
 - NASM21060L4 Nutplate (CRES)
- (e) The CWR support struts shall require 12 additional fastener holes located in the CWP in order to attach the strut fittings and 45° struts to both ends and center position along the bottom of the rack. The locations of these three hardpoints on the CWP are shown in Figure 3.1-3. These locations may also be used as strain relief hard points, if necessary.
- NOTE: The strut lug fittings (3 places) will be permanently attached to the CWP and should not be removed when removing a CWR and struts. The fittings are shown in Figure 3.1-6.
- Each of the 12 strut fitting-to-CWP attachment points shall be through holes in the CWP with a diameter of 0.217 inches \pm 0.004 in. [5.5mm \pm

VERIFY THAT THIS IS THE CORRECT VERSION BEFORE USE

0.1mm].

- Strut fitting-to-CWP attachment hardware as follows (12 places):
 - NAS6303U11 Bolt (CRES)
 - MS1149D0363K Washer (Alum)
 - NASM21043-3 Nut (CRES)
- Strut-to-Strut fitting (lug end) attachment hardware as follows (3 places):
 - NAS6306U9Y Bolt (CRES) (0.031" oversize dia.)
 - MS14226-32KD616 Washer (Alum) (oversize ID)
 - NASM21043-6 Nut (CRES)
- The CWR support struts are fabricated from non-conducting composite material which will electrically isolate the CWR from the CWP.

(f) Weight requirements are as follows:

- The total weight of a CWR installation shall be between 220 lbs (100 kg) and 330 lbs (150 kg) inclusive. The weight of the installation includes the empty CWR, SI payload, and associated CWR-to-CWP mounting hardware (e.g., struts, brackets, spacers, fasteners, etc.).
- The weight of an empty CWR is 83 lbs. The weight of the associated CWR-to-CWP mounting hardware is 14 lbs.
- Therefore, the total weight of the SI payload in the CWR must be between 123 lbs (55.8 kg) and 233 lbs (105.7 kg) inclusive. SI payload in the CWR includes: SI equipment, SI mounting hardware, fasteners, cables that interface between payload equipment within the CWR, and any Electronic Interface Channels or ballast weights used.
 - If the total weight of SI equipment, SI mounting hardware and fasteners, SI cables that interface between payload equipment within the CWR, and any Electronic Interface Channels used is less than 123 lbs (55.8 kg), supplemental ballast weights must be added to compensate at the very least to the 123 lb (55.8 kg) minimum. SSMOC-SCIN-DWG-3200.01 shows a single ballast weight and its dimensions.
 - If no SI electronics equipment is installed, then supplemental ballast weights in total between 123 lbs (55.8 kg) and 233 lbs (105.7 kg) shall be installed into an empty CWR by NASA. SSMOC-SCIN-DWG-3200.00 shows a CWR configuration with ballast weights installed.

(g) The center of gravity (C.G) of the populated rack (excluding CWR-to-CWP mounting hardware) must be within the center of gravity envelope stated in ICD SI_CWR_01, Section 3.1 b. The populated rack includes the SI payload (defined in Section 3.1 f) and the CWR structure. Refer to ICD SI_CWR_01, Section 3.1 b, for the allowable populated CWR C.G. envelope and the C.G. of the empty CWR structure.

(h) Four (4) hard point attachment locations for cable routing and strain relief located per Figure 3.1-3.

VERIFY THAT THIS IS THE CORRECT VERSION BEFORE USE

- Each hard point shall consist of a through hole 0.217 inch dia. +/- 0.004" (5.5 mm +/- 0.1 mm).
- Strain relief attachment hardware as follows:
 - NAS6303U(x) Bolt (CRES) (x = grip length, as required)
 - NAS1149D0363K Washer (Alum)
 - NASM21043-3 Nut (CRES)
- (i) Two (2) alignment dowel pins attached to the CWP to assist in mounting the CWR. The locations of the alignment dowel pins are shown in Figures 3.1-3 and 3.1-4. The pins are detailed in Figure 3.1-7.
 - Each dowel pin attach point shall consist of a through hole 0.413 inch dia. +/- 0.008" (10.5 mm +/- 0.2 mm).
 - Each dowel pin will be electrically isolated as shown in Figure 3.1-8.
 - Dowel pin attachment hardware as follows:
 - NAS1149D0663K Washer (Alum)
 - NAS 1805-6 Nut (CRES)

CWR shown at its location on the forward side of the CWP. Details on attachment points in Figures 3.1-2, 3.1-3, and 3.1-5.

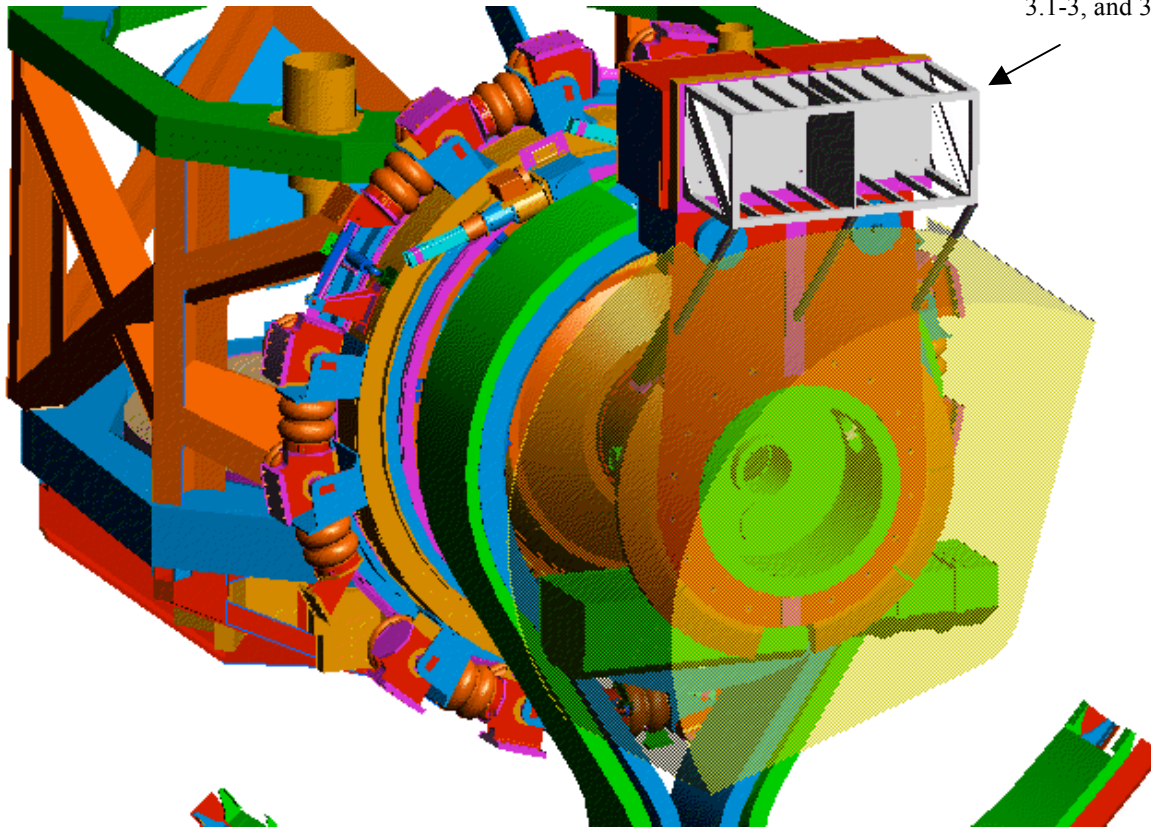
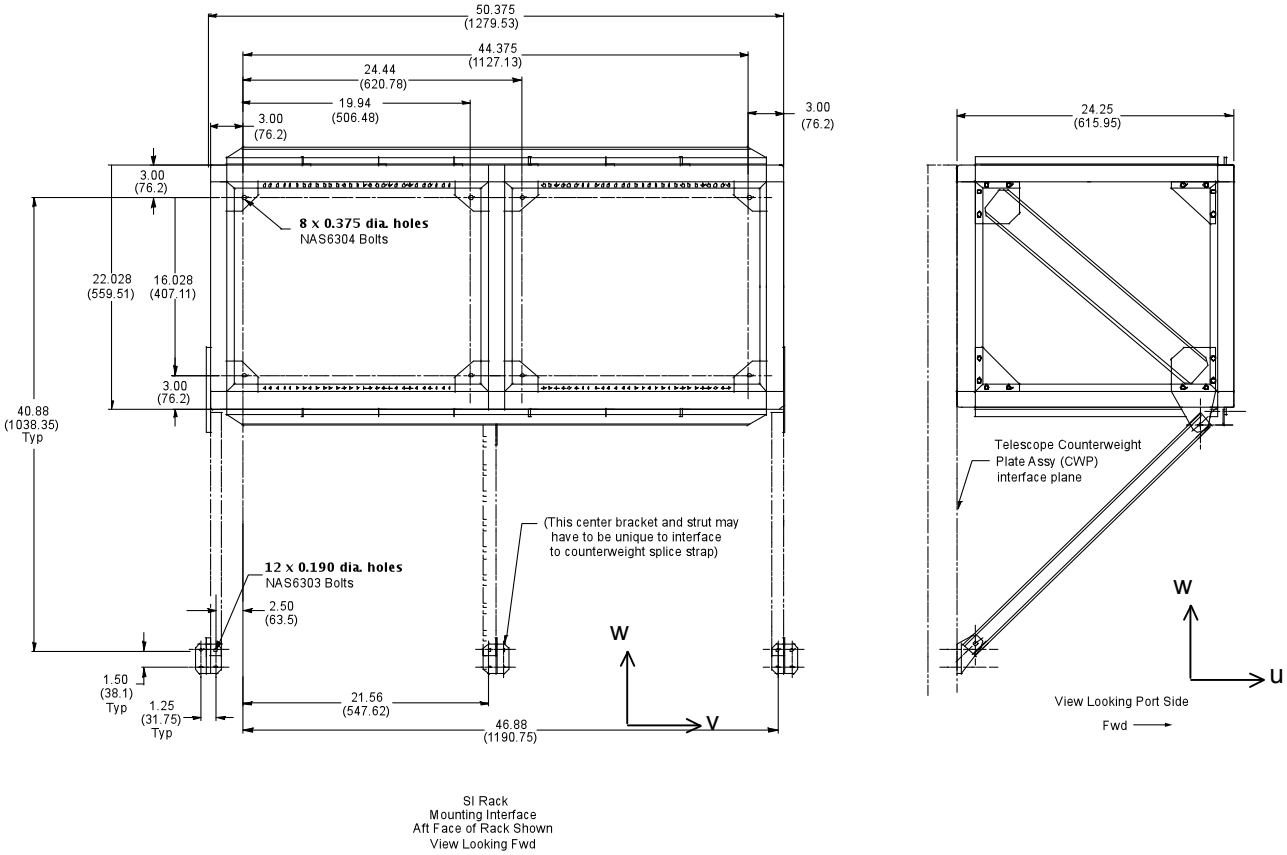

Figure 3.1-1 Location of counterweight rack (CWR) on counterweight plate (CWP)

VERIFY THAT THIS IS THE CORRECT VERSION BEFORE USE



Note: Dimensions without parenthesis are in inches and dimensions with parenthesis are in mm.

Figure 3.1-2 Counterweight rack (CWR) Installation.

VERIFY THAT THIS IS THE CORRECT VERSION BEFORE USE

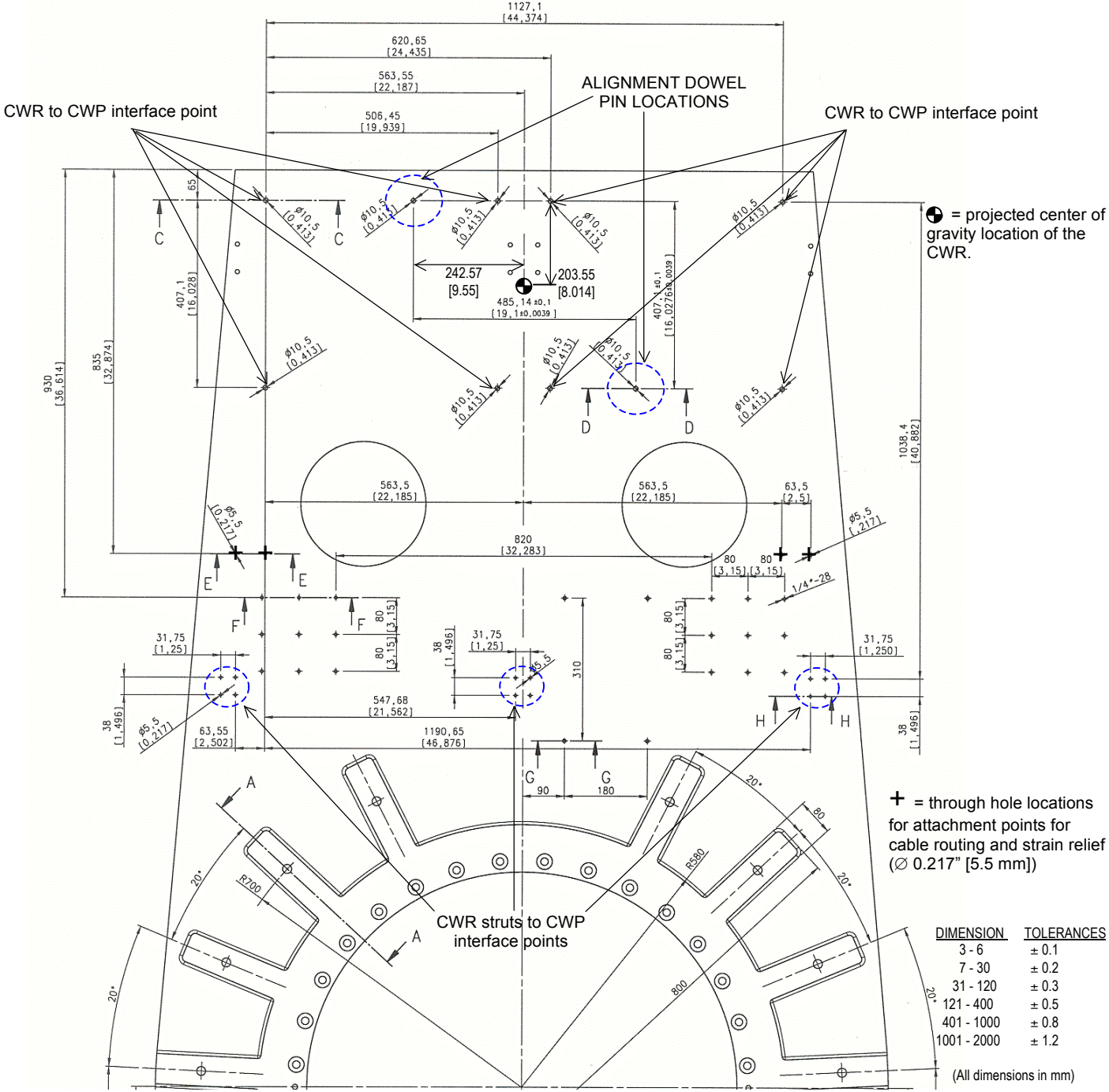

Note: All dimensions without brackets are in mm and all dimensions with brackets are in inches. Tolerances for fastener holes are located in Section 3.1.

Figure 3.1-3 Detail of attachment locations for CWR to CWP.

VERIFY THAT THIS IS THE CORRECT VERSION BEFORE USE

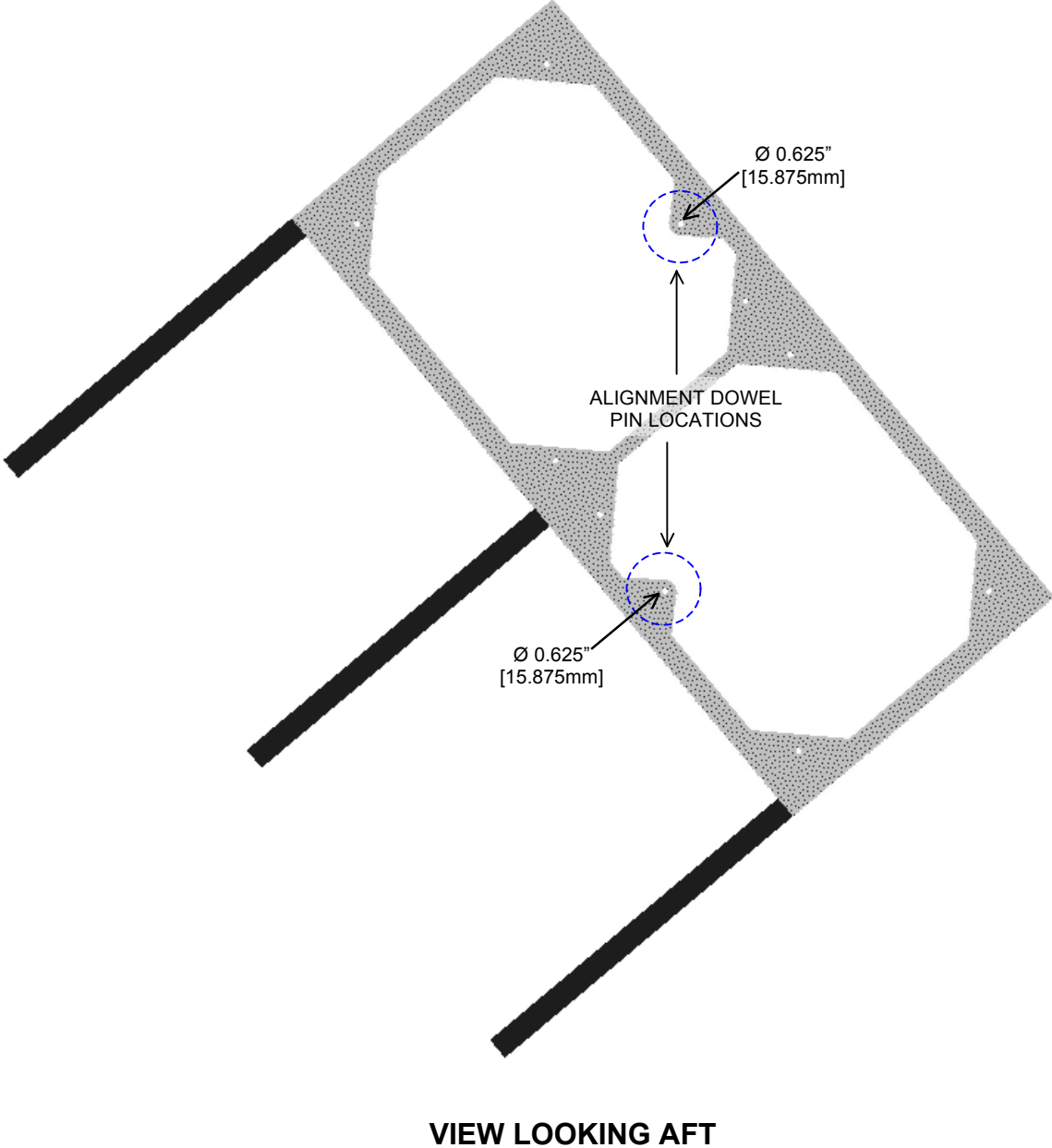
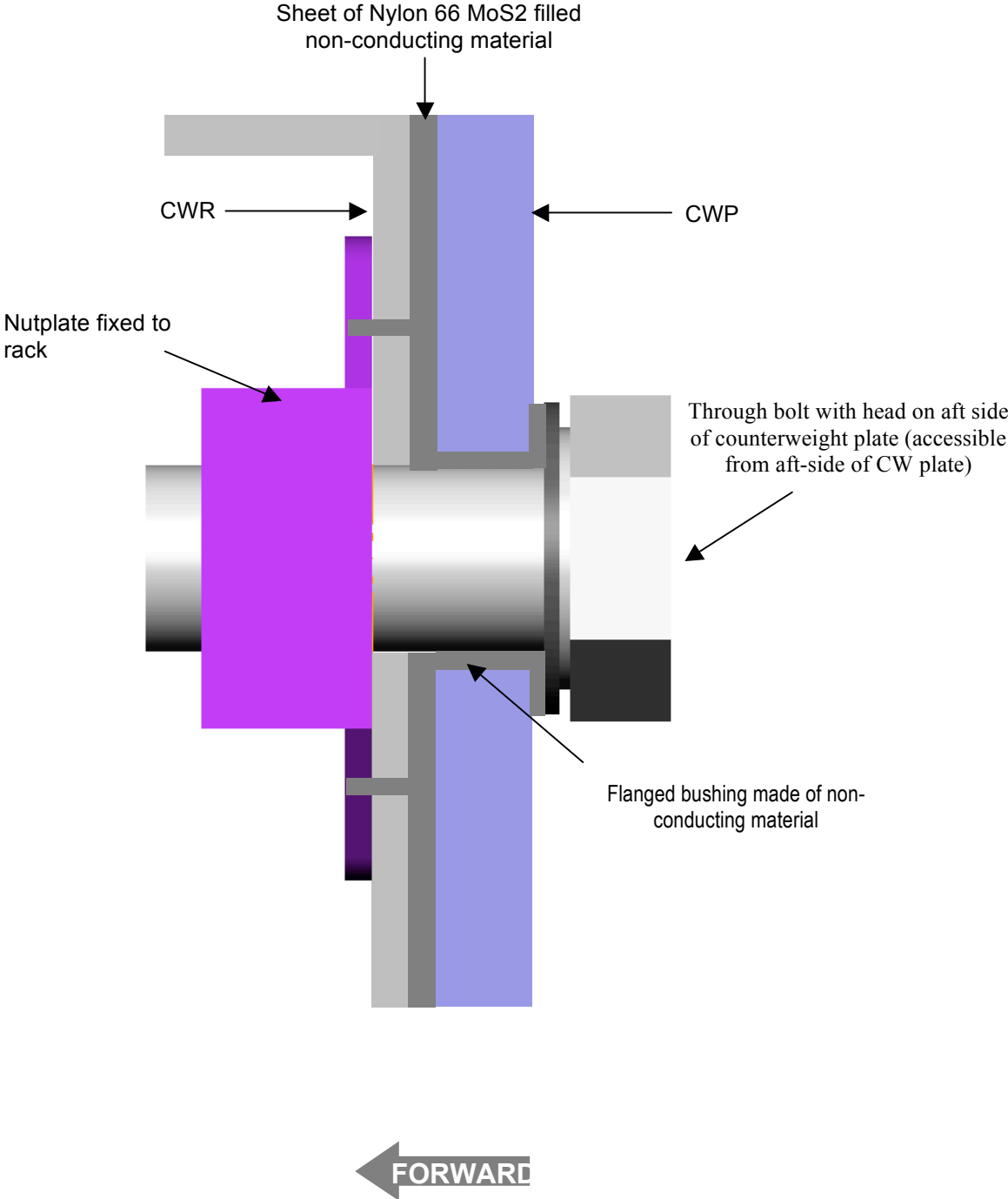

Figure 3.1-4 CWR alignment dowel pin locations showing CWR orientation with TA at 40° position.

VERIFY THAT THIS IS THE CORRECT VERSION BEFORE USE



NOTE: Materials for Electrical Isolation will be furnished by NASA after integration and are not part of the TA deliverables.

Figure 3.1-5 Counterweight rack (CWR) attachment and electrical isolation concept.

VERIFY THAT THIS IS THE CORRECT VERSION BEFORE USE

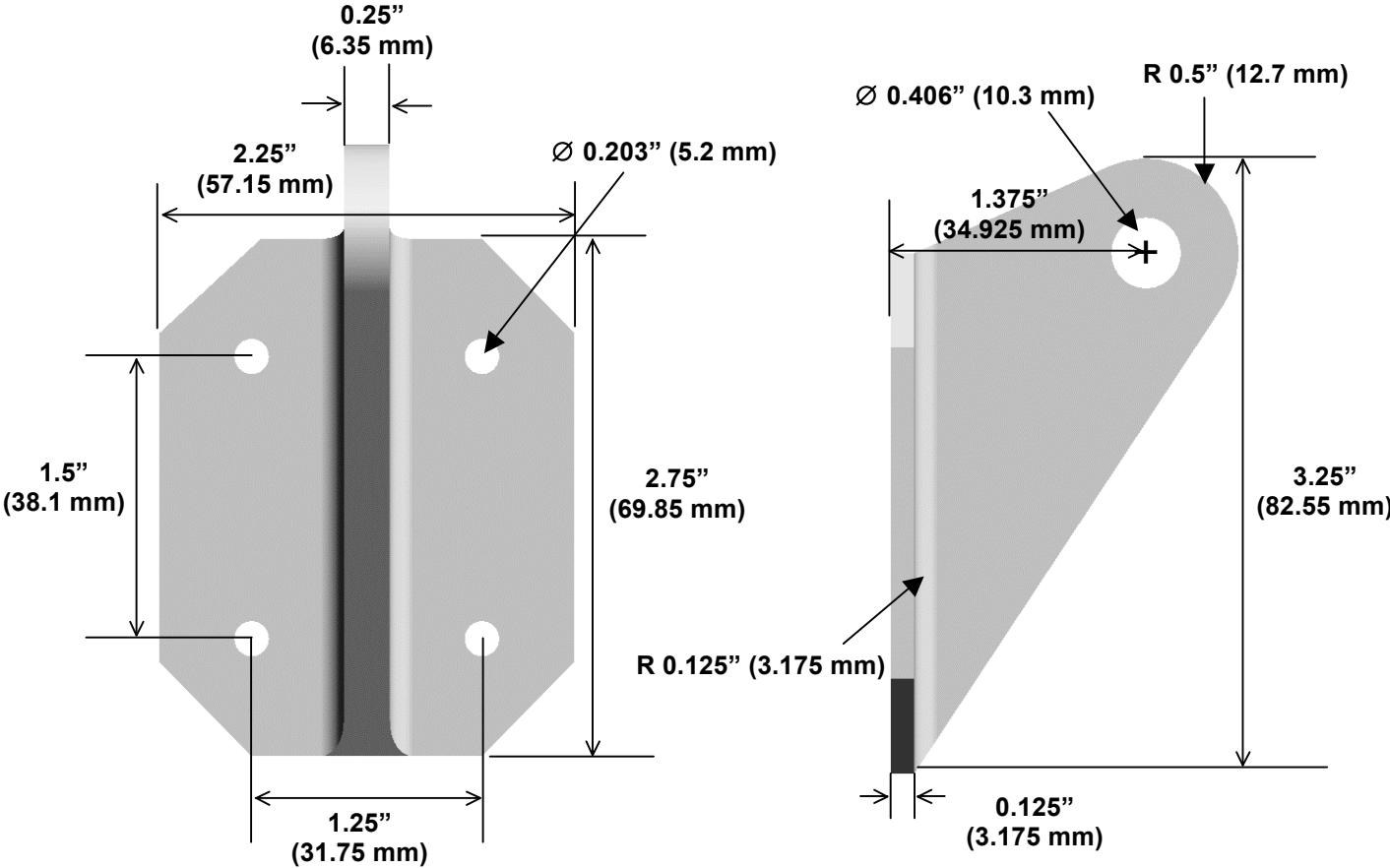

Figure 3.1-6 CWP Strut Attachment bracket.

(Three brackets required, attaching lower ends of struts to fwd side of CWP)

VERIFY THAT THIS IS THE CORRECT VERSION BEFORE USE

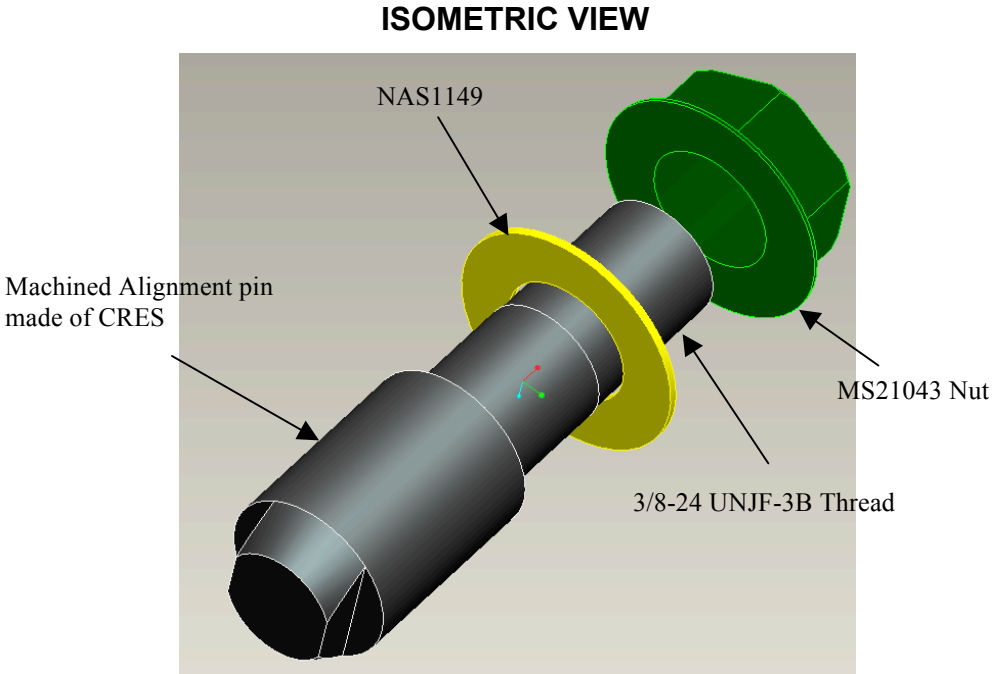
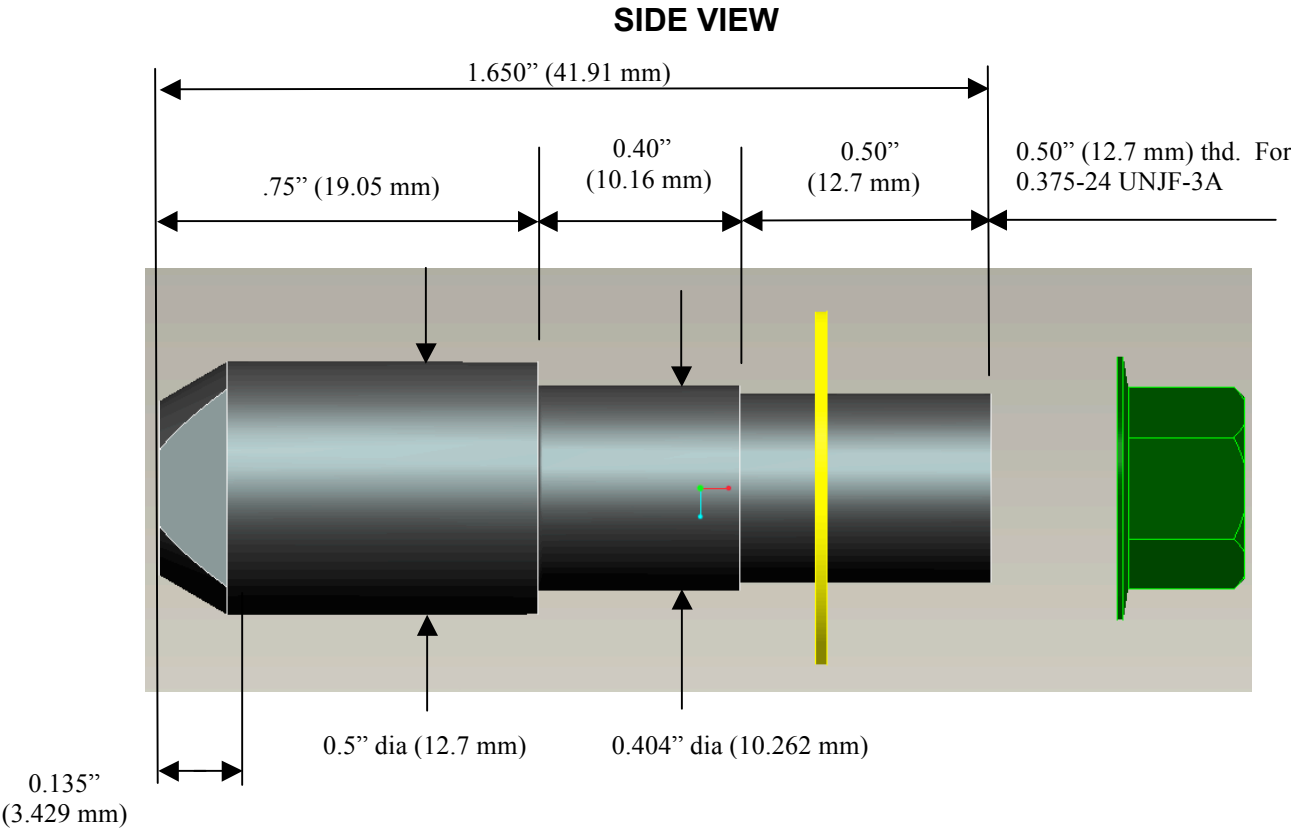

Figure 3.1-7 CWR alignment dowel pins.

VERIFY THAT THIS IS THE CORRECT VERSION BEFORE USE

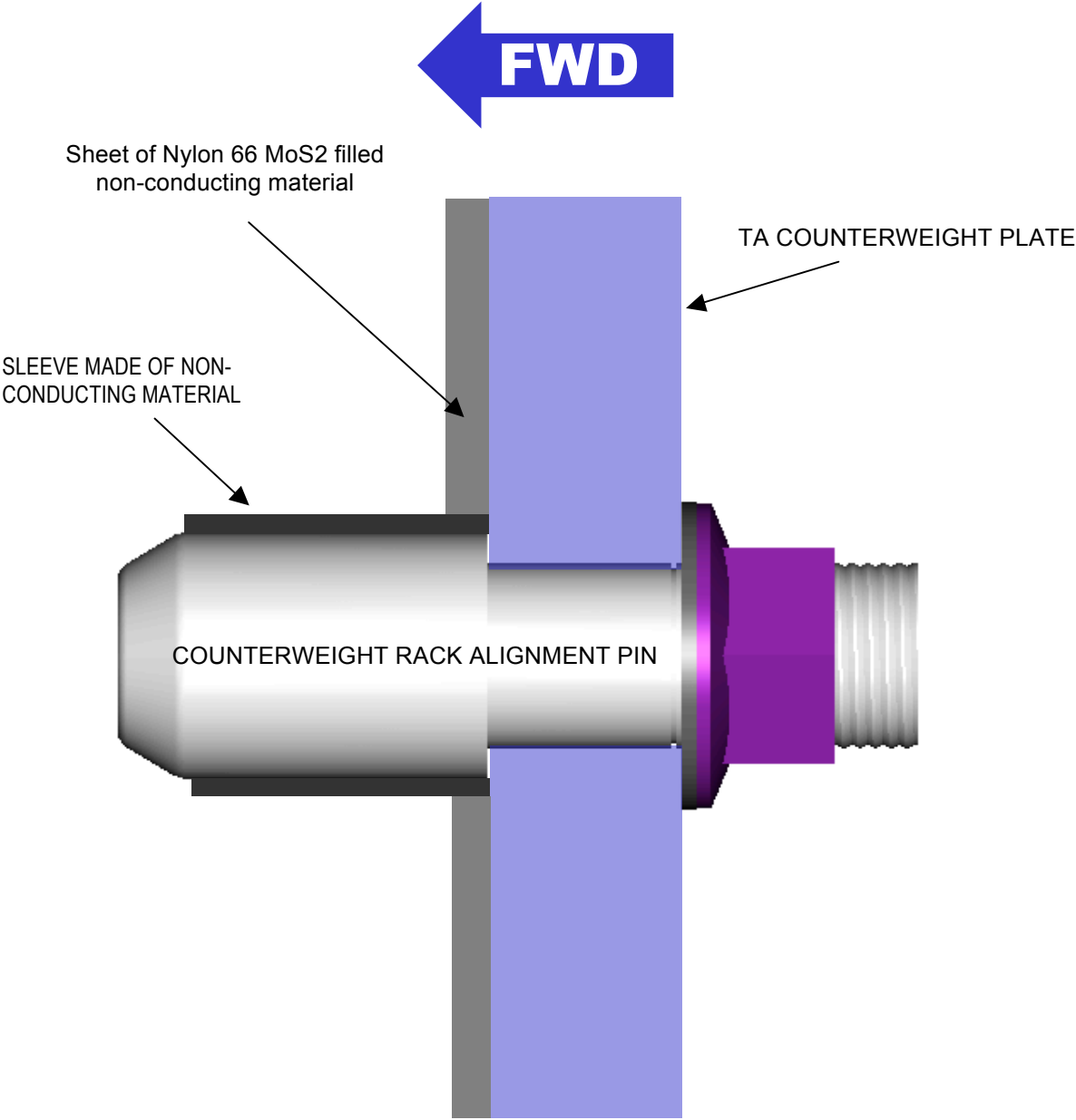

Figure 3.1-8 Alignment Pin Electrical Isolation

VERIFY THAT THIS IS THE CORRECT VERSION BEFORE USE

3.2 Functional

3.2.1 Electrical

- (a) The CWR shall be electrically isolated from the CWP through the use of strategically placed non-conducting material. (See Figures 3.1-5 and 3.1-8). Material for electrical isolation of the CWR will be furnished and installed by NASA.
- (b) The resistance from the conductive CWR structure to the U402 ground terminal strip shall be no greater than 10 m Ω (0.010 ohms). A ground connection between the CWR and the U402 ground terminal strip will be made via a ground cable assembly to be provided and installed by NASA.
- (c) SI developers are responsible for other connections, i.e., power and data cables from CWR equipment to junction boxes on the TA.

3.2.2 Hydraulic and Pneumatic

SI developers utilizing any hydraulic or pneumatic components shall be responsible to provide for any hoses, lines, tubing, and associated connecting hardware. Routing and strain relief of lines and tubes may share the four (4) hard point attachment locations for cables as shown in Figure 3.1-3.

3.3 Environmental

3.3.1 Interface Loads

- (a) Interface loads requirements shall hold only for those in-flight and ground conditions given in SOF-1030/DCR-0012 Rev. 5. In particular, the aircraft motions/loads given in DCR-0012 Rev 5, Section 9.2, as they are transmitted to the telescope and the CWP via the Vibration Isolation System (VIS) and Rotation Isolation System (RIS).
- (b) The CWR structure and interface attach fasteners must be designed to withstand required inertial loads as well as emergency landing loads. Additional Aircraft Motions/Loads are specified in DCR-0012 Rev 5 Par. 9.1.

3.3.2 Vibration Isolation

If necessary, vibration isolation shall be provided by the equipment provider for any component that cannot tolerate the vibration levels specified in Section 4.9.2 of SE03-037 (TA_SI_02).

VERIFY THAT THIS IS THE CORRECT VERSION BEFORE USE

3.3.3 Heat Dissipation

Any heat generated by electronics mounted in the CWR shall be dissipated within the aircraft cabin and shall have no negative consequences on the TA thermal requirements as stated in Section 4.7.1 of SE03-037 (TA_SI_02).

3.4 Safety

Safety related interface requirements in this ICD are covered by SCI-AR-PLA-PM21-2000 (Science Project System Safety Mission Assurance Plan).

4.0 Quality Assurance Provisions

Quality Assurance will verify each hardware interface to the drawing, and participate in testing by reviewing and verifying plans and procedures; witnessing tests; and approving reports in accordance with SCI-AR-PLA-PM21-2000.

5.0 Definitions, Abbreviations, Acronyms

The definitions, abbreviations, and acronyms used in this document are referenced in the SOFIA Lexicon, PD-2009.

CG	Center of Gravity
CWP	Counterweight Plate
CWR	Counterweight Rack
ICD	Interface Control Document
LH	Left-hand
RH	Right-hand
SI	Science Instrument
SSMO	SOFIA Science and Mission Operations
TA	Telescope Assembly

6.0 Notes

The following notes present information of a general nature which although related to this ICD, are not considered to be ICD requirements.

- 1) The CWR is considered to be a part of the SI, and as such should be installed just prior to a defined series of flights and removed just after completion of the flights. The CWR installation is depicted in Figure 3.1-2.
- 2) The CWR is not equipped with lift fixtures for mounting and ground handling purposes. The SSMO will provide lift fixtures and a lifting device to accomplish installation of the CWR. In addition, an installation procedure will be developed for mounting and installing a CWR to insure the safety of equipment and personnel. This document will follow from those developed for SI installation.

VERIFY THAT THIS IS THE CORRECT VERSION BEFORE USE

- 3) As a goal the CWR should be designed such that there are no free-free (i.e. unconstrained) vibrational modes less than 100 Hz.